



**Agilent 34980A
Multifunction
Switch/Measure Unit**

Service Guide

Notices

© Agilent Technologies, Inc. 2006

No part of this manual may be reproduced in any form or by any means (including electronic storage and retrieval or translation into a foreign language) without prior agreement and written consent from Agilent Technologies, Inc. as governed by United States and international copyright laws.

Manual Part Number

34980-90010

Edition

Second Edition, June 2011

Printed in Malaysia

Agilent Technologies, Inc.
3501 Stevens Creek Blvd
Santa Clara, CA 95052 USA

Microsoft® and Windows® are U.S. registered trademarks of Microsoft Corporation.

Software Revision

This guide is valid for the firmware that was installed in the instrument at the time of manufacture. However, upgrading the firmware may add or change product features. For the latest firmware and documentation, go to the product page at:

www.agilent.com/find/34980A

Warranty

The material contained in this document is provided “as is,” and is subject to being changed, without notice, in future editions. Further, to the maximum extent permitted by applicable law, Agilent disclaims all warranties, either express or implied, with regard to this manual and any information contained herein, including but not limited to the implied warranties of merchantability and fitness for a particular purpose. Agilent shall not be liable for errors or for incidental or consequential damages in connection with the furnishing, use, or performance of this document or of any information contained herein. Should Agilent and the user have a separate written agreement with warranty terms covering the material in this document that conflict with these terms, the warranty terms in the separate agreement shall control.

Technology Licenses

The hardware and/or software described in this document are furnished under a license and may be used or copied only in accordance with the terms of such license.

Restricted Rights Legend

U.S. Government Restricted Rights. Software and technical data rights granted to the federal government include only those rights customarily provided to end user customers. Agilent provides this customary commercial license in Software and technical data pursuant to FAR 12.211 (Technical Data) and 12.212 (Computer Software) and, for the Department of Defense, DFARS 252.227-7015 (Technical Data - Commercial Items) and DFARS 227.7202-3 (Rights in Commercial Computer Software or Computer Software Documentation).

Safety Notices

CAUTION

A **CAUTION** notice denotes a hazard. It calls attention to an operating procedure, practice, or the like that, if not correctly performed or adhered to, could result in damage to the product or loss of important data. Do not proceed beyond a **CAUTION** notice until the indicated conditions are fully understood and met.

WARNING

A **WARNING** notice denotes a hazard. It calls attention to an operating procedure, practice, or the like that, if not correctly performed or adhered to, could result in personal injury or death. Do not proceed beyond a **WARNING** notice until the indicated conditions are fully understood and met.

Additional Safety Notices

The following general safety precautions must be observed during all phases of operation of this instrument. Failure to comply with these precautions or with specific warnings or instructions elsewhere in this manual violates safety standards of design, manufacture, and intended use of the instrument. Agilent Technologies assumes no liability of the customer's failure to comply with the requirements.

General

Do not use this products in any manner not specified by the manufacturer. The protective features of this product may be impaired if it is used in a manner not specified in the operation instructions.

Before Applying Power

Verify that all safety precautions are taken. Make all connections to the unit before applying power.

Ground the Instrument

This product is provided with protective earth terminals. To minimize shock hazard, the instrument must be connected to the ac power mains through a grounded power cable, with the ground wire firmly connected to an electrical ground (safety ground) at the power outlet. Any interruption of the protective (grounding) conductor or disconnection of the protective earth terminal will cause a potential shock hazard that could result in personal injury.

Do Not Operate in an Explosive Atmosphere

Do not operate the instrument in the presence of flammable gases or fumes.

Do Not Remove the Instrument Cover

Only qualified, service-trained personal who are aware of the hazards involved should remove instrument covers. Always disconnect the power cable and any external circuits before removing the instrument cover.

Do Not Modify the Instrument

Do not install substitute parts or perform any unauthorized modification to the product. Return the product to an Agilent Sales and Service Office for service and repair to ensure that safety features are maintained.

In Case of Damage

Instruments that appear damaged or defective should be made inoperative and secured against unintended operation until they can be repaired by qualified service personnel.

Safety Symbols



Alternating current



Frame or chassis terminal



Standby supply. Unit is not completely disconnected from ac mains when switch is off



Caution, risk of electric shock



Caution, refer to accompanying

Waste Electrical and Electronic Equipment (WEEE) Directive 2002/96/EC



This product complies with the WEEE Directive (2002/96/EC) marking requirement. The affixed product label (see above) indicates that you **must not discard this electrical/electronic product in domestic household waste.**

Product Category: With reference to the equipment types in the WEEE directive Annex 1, this product is classified as a "Monitoring and Control instrumentation" product.

To return unwanted products, contact your local Agilent office, or go to www.agilent.com/environment/product for more information.

Technical Support

If you have questions about your shipment, or if you need information about warranty, service, or technical support, contact Agilent Technologies:

In the United States: (800) 829-4444

In Europe: 31 20 547 2111

In Japan: 0120-421-345

Or go to www.agilent.com/find/assist for information on contacting Agilent in your country of specific location. You can also contact your Agilent Technologies Representative.

Front Panel at a Glance

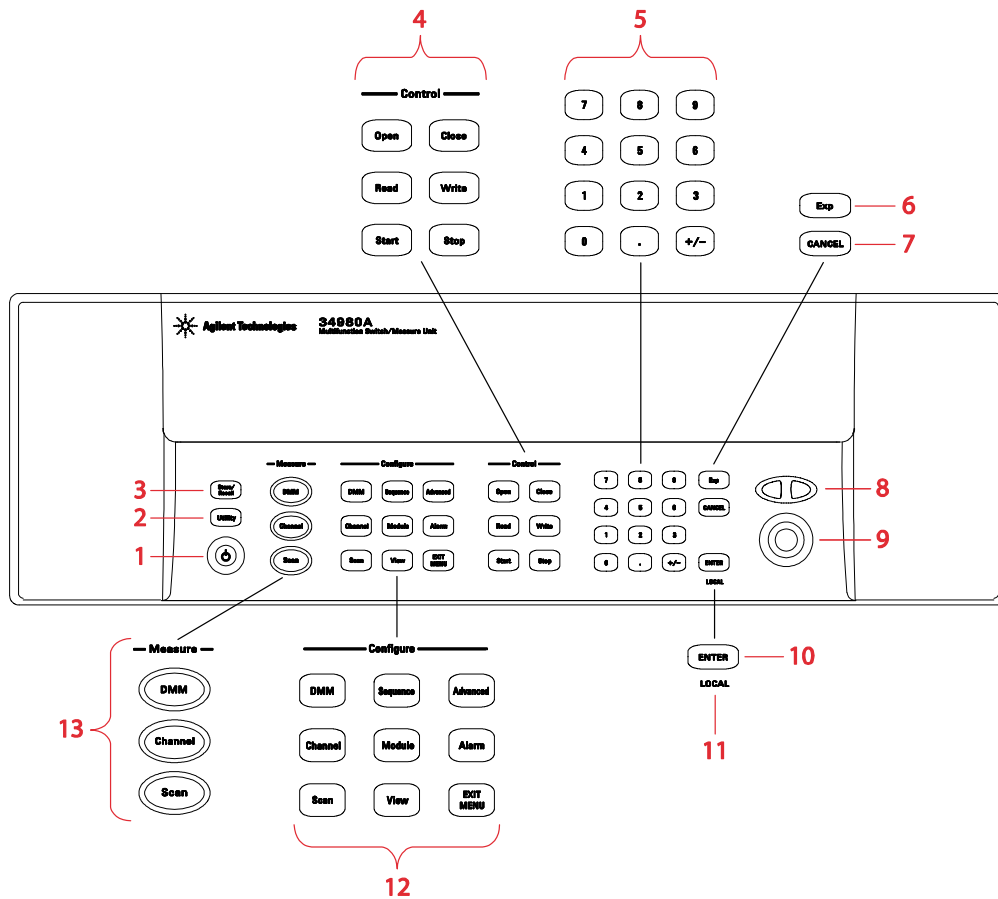

- 1 On/Standby switch **WARNIN** . This switch is standby only. To disconnect the mains from the instrument, remove the power cord.
- 2 Utility menu contains settings for Remote I/O (LAN, GPIB, and USB), Date and Time, and other system-related instrument parameters
- 3 Store/recall menu allows you to save and recall up to six instrument setups
- 4 Control keys directly control module actions
- 5 Number keypad enters numerical characters
- 6 Exponent
- 7 Cancel key exits a menu without saving changes
- 8 Arrow keys move cursor positions
- 9 Knob enters alphanumeric characters, selects slots, channels, and navigates menus
- 10 Enter key steps you through a menu or saves number entries
- 11 Running a program puts the display into “remote” and disables the front panel keys. Local takes you out of “remote” mode and enables the front panel keys.
- 12 Configure keys select functions and set function parameters
- 13 Measure keys execute and monitor measurements. Depending on which measurement key you use, you can have complete/direct control over the switching and measurement operation, or you can have the 34980A automatically control these to capture the desired data.

Rear Panel at a Glance

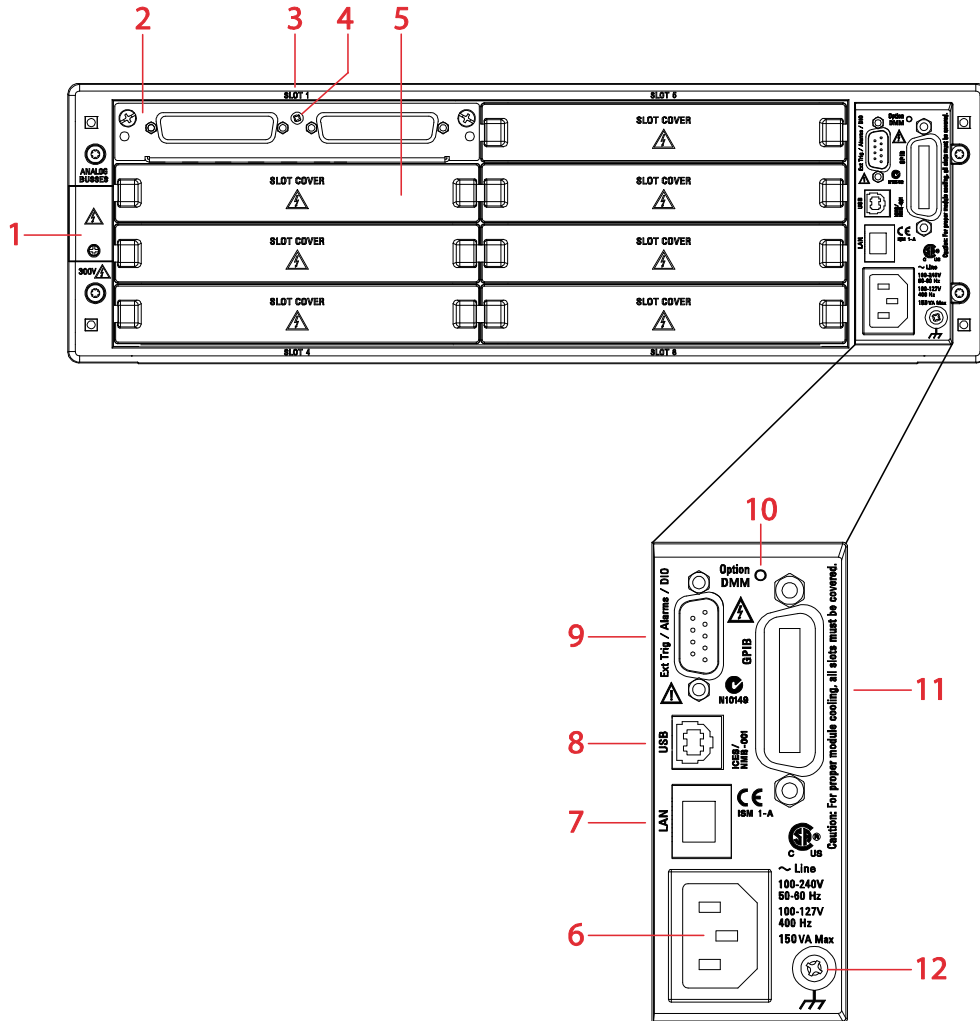

- 1 Access to Analog Buses (shown with cover installed). For pinout, see [page vi](#).
- 2 Module installed in slot 1
- 3 Slot identifier
- 4 Module ground screw
- 5 Slot cover over slot 2
- 6 AC power connector
- 7 LAN connector (10Base T/100Base Tx)
- 8 USB 2.0 connector
- 9 External trigger input. For pinout, see [page vi](#).
- 10 Internal DMM option mark. If you ordered the internal DMM option, the circle is marked black.
- 11 IEEE 488.2 GPIB Connector
- 12 Chassis ground screw

Rear Panel Connector Pinouts

External Trigger/Alarms Connector (Male D-Sub)

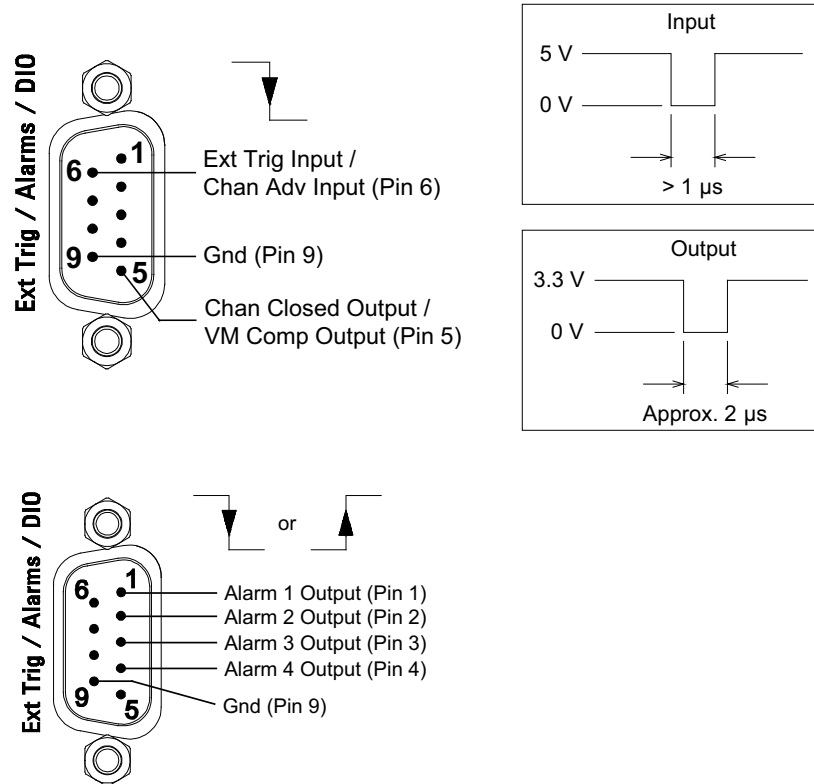

Analog Bus Connector (Female D-Sub)

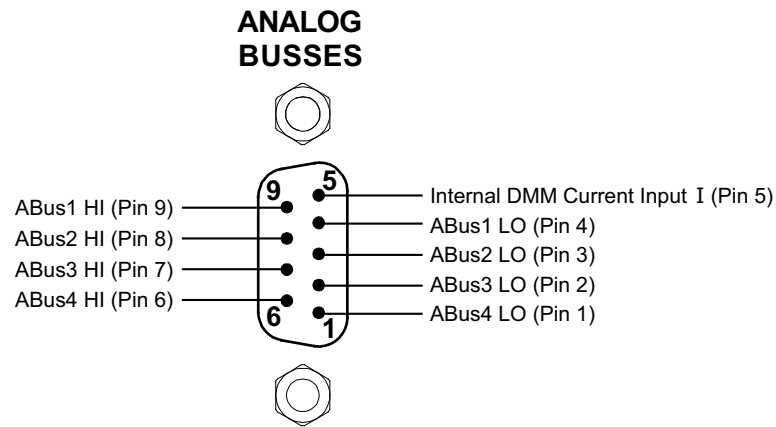

Annunciator Display Indicators

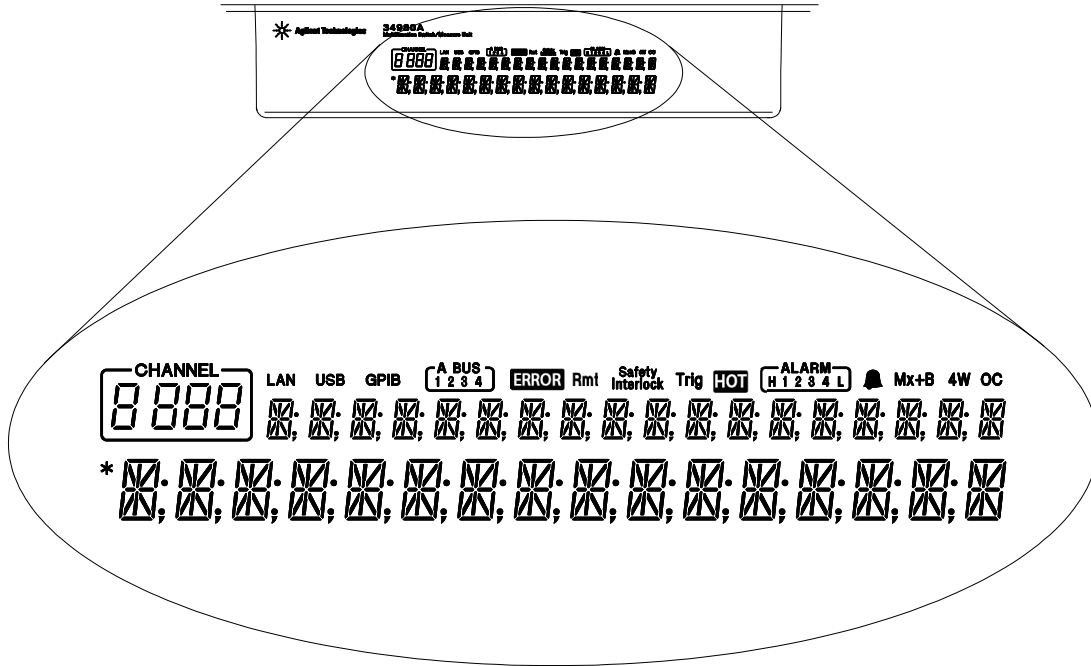

Display Indicator	Definition
LAN	Communicating with the 34980A over LAN.
USB	Communicating with the 34980A over USB.
GPIB	Communicating with the 34980A over GPIB.
ABUS [1234]	Analog Bus Connectivity. Normally, designated ABus connected on any module in mainframe. During scan, if ABus 1 and ABus 2 are indicated, they will be used at some point during the scan.
ERRO	An error has been generated and is in the error queue.
Rmt	Remote. Running a program puts the display into “remote” and disables the front panel keys. Pressing the LOCAL button takes you out of “remote” mode and enables the front panel keys.
Safety Interlock	ABus Safety Interlock. Terminal block or cables have been removed from the D-sub connector of a module. For more information, see the Agilent 34980A User’s Guide.
Trig	Waiting for external or manual trigger during scans.
HO	Over-temperature condition. One or more general purpose (34937A/34938A) modules have reached their over-temperature limits.
ALARM (H1234L)	HI or LO alarm condition has occurred on the indicated alarms.
	Alarms are enabled on the displayed channel.
Mx+B	Scaling enabled on channel. This appears on display after you select scaling function via front panel or remote interface.
4W	4-wire measurement specified on channel. This appears on display after you select the 4-wire function via the front panel or remote interface.
OC	Offset Compensation specified on channel. This appears on display after you have selected the offset compensation function via the front panel or remote interface.
*	Measurement is in progress.

Front Panel Menu Reference

This section gives an overview of the top two levels of menus that you access from the front panel. The menus are designed to automatically guide you through all parameters required to configure a particular function or operation.

Store/Recall Store and recall instrument states

- Store up to six instrument states in non-volatile memory
- Assign a name to each storage location.
- Recall stored states, power-down state, factory reset state, or preset state

Utility Configure system-related instrument parameters

- Connecting and configuring to use with LAN, GPIB, or USB
- Set the real time clock and calendar
- Set radix character, thousand separator
- Enable/disable the internal DMM
- Query and update the firmware revisions for the mainframe and modules

Configure Key Group Set parameters for measurement

DMM

- Set DMM measurement function (AC volts, DC volts, AC current, DC current, 2-wire ohms, 4-wire ohms, temperature, frequency, and period)
- Set function parameters

Channel

- Set channel measurement function (AC volts, DC volts, AC current (34921A only), DC current (34921A only) 2-wire ohms, 4-wire ohms, temperature, frequency, and period)
- Set function parameters

Scan

- Set up trigger-in parameters
- Set up sweep count
- Set up sample count

Sequence

- View sequence command string
- Execute sequence
- Delete sequence definitions

Module

- Open all relays
 - Clear all measurement functions
 - Clear channel labels
 - Configure external trigger and clock (34951A)
 - Set trace or level mode (34951A)
 - Set waveform parameters (34951A)
-

View

- View errors and alarms
- Read the number of cycles for the displayed relay (relay maintenance feature)

Advanced

Available at a later firmware release

Alarm

- Select one of four alarms to report alarm conditions on the displayed channel
 - Configure a high limit, a low limit, or both for the displayed channel
 - Select the slope (rising or falling edge) for the four alarm output lines
-

Instrument Rack Mounting

Using the optional Agilent Y1130A Rack Mount Kit, you can mount the 34980A in a standard 19-inch rack cabinet. This kit includes rack mount brackets and associated hardware required to forward or reverse mount the instrument in the rack cabinet.

- For *forward* rack mounting (34980A front panel facing the front of the cabinet), use the Agilent standard rack mount kit (part number 5063-9214). For Agilent rack cabinets, use the E3663A Basic Rail Kit (sold separately).
- For *reverse* rack mounting (34980A rear panel facing the front of the cabinet), use the longer brackets (see figure below) with the hardware for the standard rack mount kit. For Agilent rack cabinets, use the E3664AC Third Party Rail Kit (sold separately).

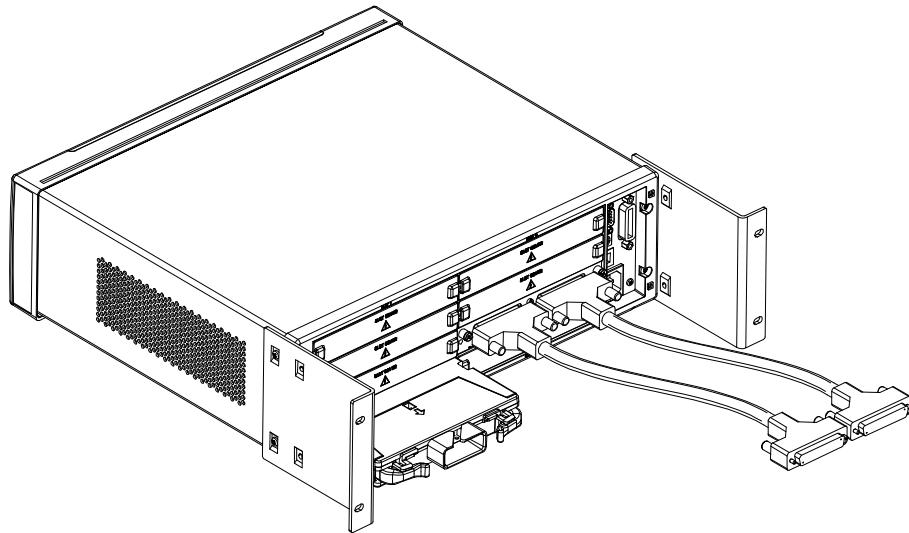

Reverse Rack Mount Orientation (longer brackets used)

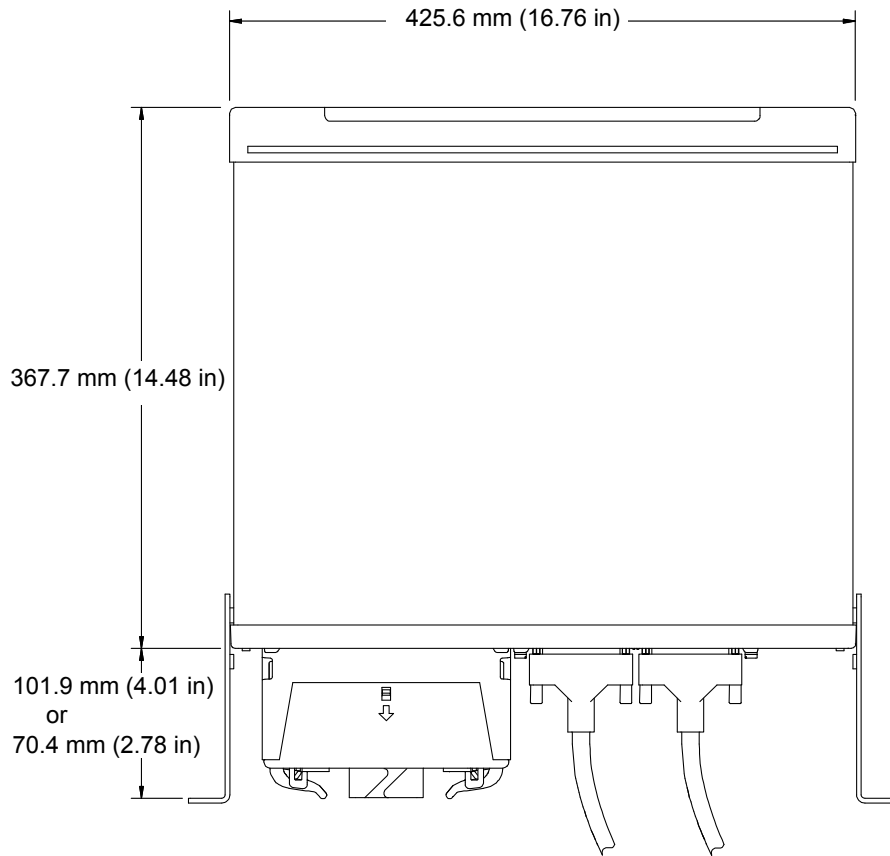

Agilent 34980A Dimensions (shown with Reverse Rack Mount brackets installed)

Contents

Front Panel at a Glance	iii
Rear Panel at a Glance	iv
Rear Panel Connector Pinouts	v
Annunciator Display Indicators	vi
Front Panel Menu Reference	vii
Instrument Rack Mounting	vii

1 Obtaining Service

Operating Checklist	6
Types of Service Available	6
Repackaging for Shipment	7
Cleaning	7
Self Test Procedures	8
Electrostatic Discharge (ESD) Precautions	9

2 Specifications

Multiplexer Module Specifications and Characteristics	12
Matrix Modules Specifications and Characteristics	14
GP Actuator Module Specifications and Characteristics	16
RF and Microwave Module Specifications and Characteristics	17
34945A/34945EXT Module Specifications and Characteristics	19
34950A 64-channel Digital I/O Specifications and Characteristics	20
34951A 4-channel D/A Converter Specifications and Characteristics	22
34952A Multifunction Module Specifications and Characteristics	24
34959A Breadboard Module Specifications and Characteristics	25
Internal DMM Specifications and Characteristics	26
Typical System Speeds	29
Internal DMM Measurement Characteristics	31
System Specifications and Characteristics	35
Product Dimensions	37
To Calculate Total DMM Measurement Error	38
Interpreting Internal DMM Specifications	40
Configuring for Highest Accuracy Measurements	42

3 Calibration Procedures

Agilent Technologies Calibration Services	44
Calibration Interval	44
Adjustment is Recommended	44
Time Required for Calibration	45
Automating Calibration Procedures	45
Recommended Test Equipment	46
Calibration Security	47
Calibration Message	48
Calibration Count	48
Calibration Process	49
Aborting a Calibration in Progress	49
Performance Verification Tests	50
Input Connections	52
DMM Test Considerations	53
Internal DMM Verification Tests	53
Optional AC Performance Verification Tests	59
Internal DMM Adjustments	60
Gain Adjustment	61
Plug-in Module Test Considerations	65
34951A 4-Ch Isolated DAC Module	66
34952A Multifunction Module	71
Relay Plug-in Modules	73
Thermocouple Reference Junction 34921A (Optional)	75

4 Troubleshooting and Diagnostics

Troubleshooting Hints	78
Power Supply	79
Product Firmware Updates	79
Instrument Errors	80
Error Numbers	82
Isolate a Problem with a Plug-In Module	90
Relay and FET Replacement	91
34921A 40-Channel Armature Multiplexer with Low Thermal Offset	92
34922A 70-Channel Armature Multiplexer	94
34923A 40/80-Channel Reed Multiplexer	96
34924A 70-Channel Reed Multiplexer	98
34925A 40/80-Channel Optically-Isolated FET Multiplexer	100
34931A Dual 4x8 Armature Matrix	102
34932A Dual 4x16 Armature Matrix	104
34933A Dual/Quad 4x8 Reed Matrix	107
34937A 32-Channel GP Switch	111
34938A 20-Channel High-Current GP Switch	112

5 Disassembly and Repair

Electrostatic Discharge (ESD) Precautions	114
Surface Mount Repair	114
Tools Required	114
Basic Disassembly	115
Power Supply Removal	116
Power Supply Disassembly	117
KOM Removal	118
Front Panel Removal	119
Front Panel Disassembly	120
DMM Removal	121
Backplane Removal	122

6 Replaceable Parts

To Order Replaceable Parts	124
Backdating and Part Changes	124
Mainframe Replaceable Parts	125
34921A Replaceable Parts	126
34922A Replaceable Parts	126
34923A Replaceable Parts	127
34924A Replaceable Parts	127
34925A Replaceable Parts	127
34931A Replaceable Parts	128
34932A Replaceable Parts	129
34933A Replaceable Parts	130
34937A Replaceable Parts	130
34938A Replaceable Parts	130
Vendor Addresses	131

7 Backdating

8 Diagrams

34921A Component Locator	136
34922A Component Locator	137
34923A Component Locator	138
34924A Component Locator	139
34925A Component Locator (Top)	140
34925A Component Locator (Bottom)	141
34931A Component Locator	142
34932A Component Locator	143
34933A Component Locator	144
34937A Component Locator	145
34938A Component Locator	146



1 Obtaining Service

Operating Checklist	6
Types of Service Available	6
Repackaging for Shipment	7
Cleaning	7
Self Test Procedures	8
Electrostatic Discharge (ESD) Precautions	9

Obtaining Service

Operating Checklist

Before returning your instrument to Agilent for service or repair check the following items:

Is the instrument inoperative?

- Verify that the power cord is connected to the instrument and to ac line power.
- Verify the front panel power switch is depressed.

Does the instrument fail self-test?

- Remove all test connections to the instrument and run the self-test again.

Errors may be induced by ac signals present on the instrument input terminals during self-test. Long test leads can act as an antenna causing pick-up of ac signals.

Types of Service Available

If your instrument fails during the warranty period, Agilent Technologies will repair or replace it under the terms of your warranty. After your warranty expires, Agilent offers repair services at competitive prices.

Extended Service Contracts

Many Agilent products are available with optional service contracts that extend the covered period after the standard warranty expires. If you have such a service contract and your instrument fails during the covered period, Agilent Technologies will repair or replace it in accordance with the contract.

Obtaining Repair Service (Worldwide)

To obtain service for your instrument (in-warranty, under service contract, or post-warranty), contact your nearest Agilent Technologies Service Center. They will arrange to have your unit repaired or replaced, and can provide warranty or repair-cost information where applicable.

To obtain warranty, service, or technical support information you can contact Agilent Technologies at one of the following telephone numbers:

In the United States: (800) 829-4444

In Europe: 31 20 547 2111

In Japan: 0120-421-345

Or use our Web link for information on contacting Agilent worldwide:

www.agilent.com/find/assist

Or contact your Agilent Technologies Representative.

Before shipping your instrument, ask the Agilent Technologies Service Center to provide shipping instructions, including what components to ship. Agilent recommends that you retain the original shipping carton for use in such shipments.

Repackaging for Shipment

If the unit is to be shipped to Agilent for service or repair, be sure to:

- Remove all accessories or plug-in modules from the mainframe.
- Attach a tag to the unit identifying the owner and indicating the required service or repair. Include the model number and full serial number.
- Place the unit in its original container with appropriate packaging material for shipping.
- Secure the container with strong tape or metal bands.
- If the original shipping container is not available, place your unit in a container which will ensure at least 4 inches of compressible packaging material around all sides for the instrument. Use static-free packaging materials to avoid additional damage to your unit.

Agilent suggests that you always insure shipments.

Cleaning

Clean the outside of the instrument with a soft, lint-free, slightly dampened cloth. Do not use detergent. Disassembly is not required or recommended for cleaning.

Self Test Procedures

Power-On Self-Test

Each time the instrument is powered on, a subset of self-tests are performed. These tests check that the minimum set of logic and output hardware are functioning properly.

Complete Self-Test

To perform a complete self-test send the `*TST?` command.

This command performs a complete self-test of the instrument and all installed plug-in modules and returns a pass/fail indication. The self-test runs a series of tests and, depending upon the modules installed, may take up to 2 minutes to complete (be sure to set an appropriate interface time out). If all tests pass, you can have a high confidence that the instrument and all installed plug-in modules are operational.

If the self-test is successful, `SELF-TEST PASSED` is displayed on the front panel.

If the self-test fails, `SELF-TEST FAILED` is displayed and an error number is shown. Self-test error numbers and their meaning are shown in the table on [page 85](#).

NOTE

The self-test will abort if any signals are connected to ABus1 via the rear-panel Analog Bus connector (pins 4, 5, and 9). Be sure to disconnect any signals from ABus1 prior to running the self-test.

- On the 34945A Microwave Switch/Attenuator Driver, this command performs a self-test of the 34945A and all connected 34945EXT remote modules.
- If you have a 34951A Isolated DAC Module installed, the self-test will require an additional 15 seconds to complete per DAC module (a memory test is performed).

If one or more tests fail, return the instrument to Agilent for service.

Self Test Error Numbers

On the remote interface, a self-test failure will generate SCPI error `-330` and a supplemental message indicating one of the test numbers shown in the table on [page 85](#).

Calibration Errors

The table on [page 86](#) shows failures that may occur during a calibration.

Electrostatic Discharge (ESD) Precautions

Almost all electrical components can be damaged by electrostatic discharge (ESD) during handling. Component damage can occur at electrostatic discharge voltages as low as 50 volts.

The following guidelines will help prevent ESD damage when servicing the instrument or any electronic device.

- Disassemble instruments only in a static-free work area.
- Use a conductive work area to reduce static charges.
- Use a conductive wrist strap to reduce static charge accumulation.
- Minimize handling.
- Keep replacement parts in original static-free packaging.
- Remove all plastic, foam, vinyl, paper, and other static-generating materials from the immediate work area.
- Use only anti-static solder suckers.

1 Obtaining Service



2 Specifications

Multiplexer Module Specifications and Characteristics	12
Matrix Modules Specifications and Characteristics	14
GP Actuator Module Specifications and Characteristics	16
RF and Microwave Module Specifications and Characteristics	17
34945A/34945EXT Module Specifications and Characteristics	19
34950A 64-channel Digital I/O Specifications and Characteristics	20
34951A 4-channel D/A Converter Specifications and Characteristics	22
34952A Multifunction Module Specifications and Characteristics	24
34959A Breadboard Module Specifications and Characteristics	25
Internal DMM Specifications and Characteristics	26
Typical System Speeds	29
Internal DMM Measurement Characteristics	31
System Specifications and Characteristics	34
Product Dimensions	36
To Calculate Total DMM Measurement Error	37
Interpreting Internal DMM Specifications	39
Configuring for Highest Accuracy Measurements	41



Multiplexer Module Specifications and Characteristics

	34921A	34922A	34923A	34924A	34925A
Channels/configurations	40 2-wire 20 4-wire 4-current 1.5 A Fused	70 2-wire 35 4-wire	80 1-wire 40 2-wire 20 4-wire	70 2-wire 35 4-wire	80 1-wire 40 2-wire 20 4-wire
Switch type	Armature latching	Armature latching	Reed	Reed	Optically isolated FET
Input characteristics (per channel)					
Max volts	$\pm 300 \text{ V}^{[1]}$	$\pm 300 \text{ V}^{[1]}$	$\pm 150 \text{ V peak}^{[2]}$	$\pm 150 \text{ V peak}^{[2]}$	$\pm 80 \text{ V peak}^{[2]}$
Max current (DC, AC RMS)					
Switch current	1 A	1 A	$0.5 \text{ A}^{[4]}/0.05 \text{ A}^{[9]}$	$0.5 \text{ A}^{[5]}/0.05 \text{ A}^{[9]}$	$0.02 \text{ A}^{[6]}$
Carry current	2 A	2 A	$1.5 \text{ A}^{[4]}/0.05 \text{ A}^{[9]}$	$1.5 \text{ A}^{[5]}/0.05 \text{ A}^{[9]}$	
Power (W, VA) ^[5]	60 W	60 W	10 W	10 W	1.6 W
Volt-Hertz limit	10^8	10^8	10^8	10^8	10^7
General specifications					
Offset voltage ^[3]	$< 3 \mu\text{V}$	$< 3 \mu\text{V}$	$< 50 \mu\text{V}$ $< 100 \mu\text{V 1-wire}$	$< 50 \mu\text{V}$	$< 3 \mu\text{V}$
Initial closed channel res ^[3]	$< 1.5 \Omega$	$< 1.5 \Omega$	$< 1.5 \Omega^{[5]}/200 \Omega^{[9]}$	$< 1.5 \Omega^{[5]}/200 \Omega^{[9]}$	$< 700 \Omega$
DC Isolation (ch-ch, ch-earth)	$>10 \text{ G}\Omega$	$>10 \text{ G}\Omega$	$>10 \text{ G}\Omega$	$>10 \text{ G}\Omega$	$>10 \text{ G}\Omega$
Leakage current ^[3]	N/A	N/A	N/A	N/A	$20 \text{ nA}^{[7]}$
T/C cold junction accuracy ^[3, 8]	$< 1 \text{ }^\circ\text{C}$	N/A	N/A	N/A	N/A

^[1] DC or AC RMS voltage, channel-to-channel or channel-to-earth

^[2] Peak voltage, channel-to-channel or channel-to-earth

^[3] Into analog bus. System errors are included in the internal DMM measurement accuracy specifications.

^[4] With in-rush resistors bypassed. Bypassing resistors reduces lifetime of relays. See the rated load relay life characteristics.

^[5] Limited to 6 W of channel resistance power loss per module

^[6] DC or peak AC current

^[7] Ambient temperature $< 30 \text{ }^\circ\text{C}$

^[8] Includes $0.5 \text{ }^\circ\text{C}$ temperature reference sensor and $0.5 \text{ }^\circ\text{C}$ terminal block isothermal gradient error. Measured under worst case loading of the mainframe. See 34980A User's Guide for information on supported external reference sensors.

^[9] With 100Ω input protection resistors.

Multiplexer Module Specifications and Characteristics (continued)

	34921A	34922A	34923A	34924A	34925A
AC characteristics					
Bandwidth at terminal block ^[1]	45 MHz	25 MHz	45 MHz ^[2] /4 MHz 10 MHz 1-wire	25 MHz ^[2] /4 MHz ^[4]	1 MHz
Crosstalk at terminal block (ch-ch) ^[1]					
300 kHz	-75 dB	-75 dB	-75 dB	-75 dB	N/A
1 MHz	-75 dB	-75 dB	-75 dB	-70 dB	
20 MHz	-50 dB	-50 dB	-50 dB	-45 dB	
45 MHz	-40 dB		-40 dB		
Capacitance at terminal block					
HI-LO	150 pF	250 pF	130 pF	200 pF	100 pF
LO - earth	150 pF	200 pF	120 pF	170 pF	300 pF (600 pF 1-wire)
General characteristics					
Relay life, typical					
No load	100 M	100 M	1000 M	1000 M	Unlimited
10 V, 100 mA	10 M	10 M	10 M	10 M	Unlimited
Rated load	100 k	100 k	10 k	10 k	Unlimited
Scanning speeds ^[3]	100 ch/sec	100 ch/sec	500 ch/sec	500 ch/sec	1000 ch/sec
Open/ close time, typical	4 ms/4 ms	4 ms/4 ms	0.5 ms/0.5 ms	0.5 ms/0.5 ms	0.25 ms/0.25 ms
Analog bus backplane connection	Yes	Yes	Yes	Yes	Yes

^[1] 50 Ω source, 50 Ω load, differential measurements verified with 4-port network analyzer (Sdd21)

^[2] With in-rush resistors bypassed. Bypassing resistors reduces lifetime of relays. See the rated load relay life characteristics.

^[3] Speeds are for 4½ digits, delay 0, display off, autozero off, and within bank.

^[4] With 100 Ω input protection resistors.

Matrix Modules Specifications and Characteristics

	34931A	34932A	34933A
Channels/configurations	dual 4x8 8x8 4x16	dual 4x16 8x16 4x32	dual 4x8 8x8 4x16 quad 4x8, 1-wire
Switch type	Armature latching	Armature latching	Reed non-latching
Input characteristics (per channel)			
Max volts	$\pm 300 \text{ V}^{[1]}$	$\pm 300 \text{ V}^{[1]}$	$\pm 150 \text{ V peak}^{[2]}$
Max current (DC, AC RMS)			
Switch current	1 A	1 A	$0.5 \text{ A}^{[4]}/0.05 \text{ A}^{[7]}$
Carry current	2 A	2 A	$1.5 \text{ A}^{[4]}/0.05 \text{ A}^{[7]}$
Power (W, VA) ^[2, 5]	60 W	60 W	10 W ^[6]
Volt-Hertz limit	10^8	10^8	10^8
General Specifications			
Offset voltage ^[3]	$< 3 \mu\text{V}$	$< 3 \mu\text{V}$	$< 50 \mu\text{V}$ $< 100 \mu\text{V 1-wire}$
Initial closed channel res ^[3]	$< 1.5 \Omega$	$< 1.5 \Omega$	$< 1.5 \Omega^{[4]}/200 \Omega^{[7]}$
DC Isolation (ch-ch, ch-earth)	$>10 \text{ G}\Omega$	$>10 \text{ G}\Omega$	$>10 \text{ G}\Omega$

^[1] DC or AC RMS voltage, channel-to-channel or channel-to-earth

^[2] Peak voltage, channel-to-channel or channel-to-earth

^[3] Into analog bus. System errors are included in the internal DMM measurement accuracy specifications.

^[4] With in-rush resistors bypassed. Bypassing resistors reduces lifetime of relays. See the rated load relay life characteristics.

^[5] Limited to 6 W channel resistance power loss per module

^[6] Power restrictions allow only 20 channels to be closed at one time.

^[7] With 100Ω input protection resistors.

Matrix Modules Specifications and Characteristics (continued)

	34931A	34932A	34933A
AC characteristics			
Bandwidth at terminal block ^[1]	30 MHz	30 MHz	30 MHz ^[2] /4 MHz ^[3] 2 MHz 1-wire
Crosstalk at terminal block (ch-ch) ^[1]			
300 kHz	-65 dB	-65 dB	-65 dB
1 MHz	-55 dB	-55 dB	-55 dB
20 MHz	-30 dB	-30 dB	-40 dB
Capacitance at terminal block			
HI-LO	50 pF	50 pF	80 pF
LO - earth	80 pF	80 pF	75 pF
General characteristics			
Relay life, typical			
No load	100 M	100 M	1000 M
10 V, 100 ma	10 M	10 M	10 M
Rated load	100 k	100 k	10 k
Open/close time	4 ms/4 ms	4 ms/4 ms	0.5 ms/0.5 ms
Analog bus backplane connection	Bank 2	Bank 2	Bank 2

^[1] 50 Ω source, 50 Ω load, differential measurements verified (Sdd21)

^[2] With in-rush resistors bypassed.

^[3] With 100 Ω input protection resistors.

GP Actuator Module Specifications and Characteristics

	34937A	34938A
Channels/configurations	28 Form C 4 Form A	20 Form A
Switch type	Armature, latching	Armature, latching
Input characteristics (per channel)		
Max volts (DC, AC RMS) ^[1]	Form C — 300 V Form A — 30 VDC/250 VAC	30 VDC/250 VAC
Max current (DC, AC RMS)	Form C — 1 A switch (2 A carry) Form A — 5 A switch (8 A carry)	5 A switch (8 A carry)
Power (W, VA) ^[2]	Form C — 60 W Form A — 150 W	150 W
Volt-Hertz limit	10 ⁸	10 ⁸
General specifications		
Offset voltage	3 μ V	3 μ V
Initial closed channel res	Form C — 125 m Ω Form A — 50 m Ω	< 60 m Ω
DC Isolation (ch-ch, ch-earth)	> 10 G Ω	> 10 G Ω
AC characteristics		
Bandwidth at terminal block ^[3]	10 MHz	1 MHz
Channel Isolation at terminal block ^[3]		
100 kHz	55 dB	60 dB
1 MHz	35 dB	40 dB
10 MHz	15 dB	
Capacitance at terminal block		
CH - CH	Form C 12 pF/ Form A 10 pF	65 pF
CH - earth	Form C 21 pF/ Form A 18 pF	105 pF
General characteristics		
Relay life no load/rated	Form C — 100 M/100 k Form A — 50 M/30 k	50 M/30 k
Open/close time	Form C — 4 ms/4 ms Form A — 10 ms/10 ms	10 ms/10 ms
Initial/reset relay state	Form C — maintain state Form A — user configurable	User configurable
Analog bus backplane connection	No	No

^[1] DC or AC RMS voltage, channel-to-channel or channel-to-earth.

^[2] Limited to 6 W of channel resistance power loss per module.

^[3] 50 Ω source, 50 Ω load, differential measurements verified (S21).

RF and Microwave Module Specifications and Characteristics

	DC to 3 GHz		DC to 20 GHz ^[2]	
	34941A	34942A	34946A	34947A
Channels	quad 1x4	quad 1x4	2 SPDT	3 SPDT
Switch type	50 Ω unterminated, latching relays	75 Ω unterminated, latching relays	50 Ω terminated	50 Ω unterminated
RF characteristics				
Frequency range ^[1]	DC to 3 GHz	DC to 1.5 GHz	DC to 4 GHz or DC to 20 GHz	DC to 4 GHz or DC to 20 GHz
Insertion loss ($< 40^{\circ}\text{C}/80\% \text{RH}$) ^[1]			DC to 4 GHz < 0.42 dB @ 20 GHz < 0.69 dB	DC to 4 GHz < 0.42 dB @ 20 GHz < 0.69 dB
100 MHz	0.15 dB	0.15 dB		
1 GHz	0.60 dB	0.60 dB		
3 GHz	1.40 dB	N/A		
VSWR			DC to 4 GHz < 1.15 @ 20 GHz < 1.30	DC to 4 GHz < 1.15 @ 20 GHz < 1.30
100 MHz	1.03	1.15		
1 GHz	1.25	1.35		
3 GHz	1.55	N/A		
Isolation (dB) ^[1]	Contact Factory	Contact Factory	DC to 4 GHz > 85 dB @ 20 GHz > 67 dB	DC to 4 GHz > 85 dB @ 20 GHz > 67 dB
100 MHz	80 dB	80 dB		
1 GHz	58 dB	60 dB		
3 GHz	40 dB	N/A		
Spurious noise below 1.3 GHz	-140 dBm	-140 dBm	80 dB	80 dB
Risetime	< 80 ps	< 160 ps	N/A	N/A
Signal delay	< 1 ns	< 1 ns	N/A	N/A
Capacitance	< 30 pF	< 30 pf	N/A	N/A

^[1] 50 Ω source, 50 Ω load (75 Ω for 34942A)

^[2] For more detailed specifications, see the N1810TL for the 34946A and N1810UL for the 34947A

2 Specifications

RF and Microwave Module Specifications and Characteristics (continued)

	DC to 3 GHz		DC to 20 GHz ^[2]	
	34941A	34942A	34946A	34947A
Switching characteristics				
Max volts ^[1]	30 V	30 V	7 V DC	7 V DC
Max current	0.5A	0.5A	N/A	N/A
Max power (W)	10 W ^[4]	10 W ^[4]	1W @ 7 VDC, 50W peak ^[3]	1W @ 7 VDC, 50W peak ^[3]
Offset voltage	10 μ V	10 μ V	N/A	N/A
Initial channel resistance	1 Ω	1 Ω	N/A	N/A
Volt-Hertz limit	2 x 10 ¹⁰	2 x 10 ¹⁰		
General characteristics				
Relay life	300,000 at 30V/10mA load; 100,000 at 10 W load RF SAmeas	300,000 at 30V/10mA load; 100,000 at 10 W load RF SAmeas	> 5 M cycles, 1M w/drive 28-32VDC	> 5 M cycles, 1M w/drive 28-32VDC
Open/Close time	18 ms / 18 ms	18 ms / 18 ms	< 15 ms / 15 ms	< 15 ms / 15 ms
Connector type	SMA	Mini 75 Ω SMB	SMA	SMA
Analog bus backplane connection	No	No	No	No

^[1] Channel-to-earth

^[2] For more detailed specifications, see the N1810TL for the 34946A and N1810UL for the 34947A

^[3] 10 μ sec maximum duration

^[4] Max power is 1 W between 30 MHz and 1 GHz for CISPR 11 compliance

34945A/34945EXT Module Specifications and Characteristics

34945EXT switch drive (64 channels, low side drive mode)	
Driver off voltage (max)	30V
Driver off leakage current	500 μ A
Driver on current (max)	600 mA
Driver on voltage (max)	0.5 V @ 600 mA
34945EXT switch drive (64 channels, TTL drive mode)	
Hi output voltage	3 V @ $I_{out} = 2$ mA
Lo output voltage	0.4 V @ $I_{in} = 20$ mA
Lo input Current	20 mA
34945EXT position indicator sense inputs	
Channels	64
Lo input voltage (max)	0.8 V
Hi input voltage (min)	2.5 V
Input resistance	> 100 k Ω @ $V_{in} \leq 5$ V > 20 k Ω @ $V_{in} > 5$ V
Maximum input voltage	30 V
34945EXT switch drive power supply (34945EXT powered by 34945A)	
Voltage	24 V nominal (external power supply required for switches needing more than 24 V)
Current	100 mA continuous + 200 mA (15 msec pulse, 25% duty cycle)
34945EXT external power connection	
Voltage range	4.75 V to 30 V
Current limit	2 A
LED indicators (current mode drivers)	
Channels	64
Supply voltage	5 V nominal
LED drive current	5 mA nominal (programmable 1 to 20 mA)
Compliance voltage	0.8 V
34945EXT Dimensions	
	11.2 x 4.5 x 1.5 inches high with distribution boards installed

34950A 64-channel Digital I/O Specifications and Characteristics

Digital input/output characteristics	
Eight 8-bit channels: 8 bits wide, input or output, non-isolated	
V _{in}	0 V – 5 V ^[1]
V _{out}	1.66 V – 5 V ^[1]
I _{out} (max)	24 mA ^[2]
Frequency (max)	10 MHz ^[3]
I _{load} (max)	400 mA
t _{rise} + t _{fall} Output (typ)	6 ns ^[4]

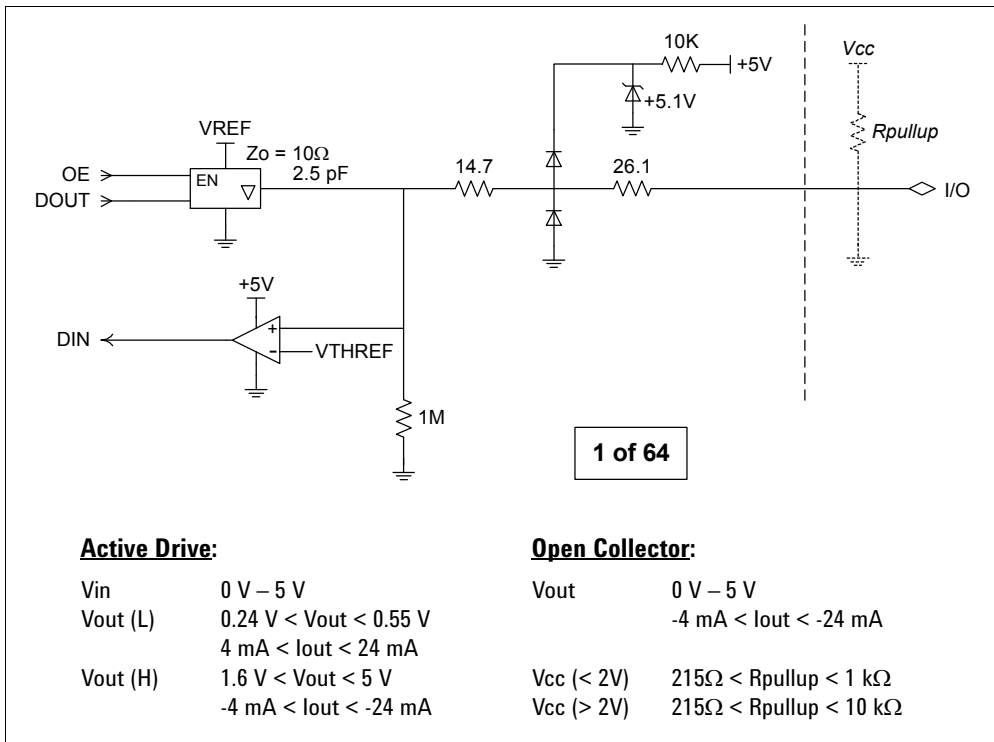

[1] Configurable by 8-bit channel

[2] Lower current drive at lower voltages

[3] From memory with handshaking

[4] 5 V, 50pF load

34950A 64-channel Digital I/O Specifications and Characteristics (continued)

Handshake lines	
V _{in}	0 V – 5 V ^[1]
V _{out}	1.66 V – 5 V ^[1,2]
I _{out} (max)	24 mA ^[2]
Frequency (max)	10 MHz
Counter function characteristics	
Maximum frequency	10 MHz (max) 50% duty
V _{in}	0 V – 5 V ^[3]
t _{rise} / t _{fall} Input (max)	5 μs
Totalizer function characteristics	
Maximum count	2 ³² – 1 (4,294,967,296)
Maximum input frequency	10 MHz rising or falling edge programmable
V _{in}	0 V – 5 V ^[3]
Gate input	0 V – 5 V ^[3]
System clock generator characteristics	
Frequency	20 MHz – 10 Hz configurable divide-by-n 24-bits, programmable on/off
V _{out}	1.66 V – 5 V ^[2]
Accuracy	100 ppm

^[1] Configurable by bank

^[2] Lower current drive at lower voltages

^[3] Maximum threshold setting of 3V

34951A 4-channel D/A Converter Specifications and Characteristics

General specifications	
Maximum update rate	200 kHz point-to-point
Monotonic	to 16-bits
Isolation	> 80 VDC/AC peak (chan-to-chassis or chan-to-chan)
Synchronization	Software commands or external trigger
Internal/external CLK accuracy	100 ppm
AC accuracy	Not specified
DC voltage	
Amplitude	± 16 V up to 10 mA
Resolution	16-bits = 500 μ V
Amplitude accuracy (DC)	$\pm (0.05\% + 3.0$ mV) 90 days, $T_{cal} \pm 5$ °C or CAL:MOD? ± 5 °C
Ripple and noise	< 2 mVrms, 20 Hz to 250 kHz into 10 k Ω load
Settling time	40 μ S (–full scale to +full scale step, single channel, to rated accuracy)
Output impedance	< 1 Ω with the load sensed
DC current	
Range	± 20 mA
Resolution	16-bit = 630 nA
Accuracy	\pm (% value + amps) temperature within ± 5 °C of T_{cal} or *CAL? 90-day: $\pm (0.09\% + 5.0$ μ A)
Ripple and noise	< 2 μ A _{rms} , 20 Hz to 250 kHz into 250 Ω
Compliance voltage	± 12 V
Max open circuit voltage	< ± 22 V

34951A 4-channel D/A Converter Specifications and Characteristics (continued)**Phase-locking I/O trigger characteristics****Trigger input**

Input level	TTL compatible (3.3 V logic, 5 V tolerant)
Slope	Rising or falling, selectable
Pulse width	> 100 nS
Input impedance	> 10 k Ω , DC coupled

Trigger output

Level	TTL compatible into 1 k Ω (3.3 V logic)
Output impedance	50 Ω typical

Clock input

Input level	TTL compatible (3.3 V logic, 5 V tolerant)
Input impedance	> 10 k Ω , DC
Maximum rate:	10 MHz

Clock output

Level	TTL compatible into 1 k Ω (3.3 V logic)
Output impedance	50 Ω typical
Maximum rate	10 MHz
Accuracy	\pm 100 ppm

34952A Multifunction Module Specifications and Characteristics

Digital input/output characteristics	
Four 8-bits channels, 8 bits wide, input or output, non-isolated	
Vin(L)	< 0.8 V (TTL)
Vin(H)	> 2.0 V (TTL)
Vout(L)	< 0.8 V @ Iout = -400 mA
Vout(H)	> 2.4 V @ Iout = 1 mA
Vin(H) (max)	< 42 V with external open drain pull-up
Alarm	Maskable pattern match or state change
Speed	4 ms (max) alarm sampling
Latency	5 ms (typical) to 34980A alarm output
Read/write speed	95/s
Totalize input characteristics	
Max count	$2^{26} - 1$
Totalize input	100 kHz (max) rising or falling edge, programmable
Signal level	1 Vp-p (min) 42 Vpk (max)
Threshold	0 V or TTL
Gate input	TTL-Hi, TTL-Lo, or none
Count reset	Manual or read + reset
Read speed	85 rds/s
Analog output characteristics	
DAC 1, 2	± 12 V, non-isolated
Resolution	1 mV
IOUT	10 mA max
Settling time	1 ms to 0.01% of output
Accuracy	\pm (% of output + mV) 1 year: \pm (0.25% + 20 mV)
Temperature coefficient	\pm (0.015% + 1mV)/°C

34959A Breadboard Module Specifications and Characteristics

General specifications	
Maximum module power dissipation	6 W
Power available	
12 V regulation no load to full load	10%
5 V regulation no load to full load	5%
Maximum power from 12 V	6 W
Maximum power from 5 V	1 W
Relay drives	28, sink up to 100 mA
GPIO ports	
Channel 1 and 2	8 configure bits as input or output
Channel 3	3 output bits
Dimensions (L x W x H)	
	5.4 x 7.5 x 0.9 inches (without PC board)
	5.4 x 7.5 x 0.7 inches (with PC board)

Internal DMM Specifications and Characteristics

DC and Resistance Specifications

DMM accuracy \pm (% of reading + % of range). Includes measurement error, switching error^[1], and transducer conversion error.

Function	Range ^[4]	Test Current or Burden Voltage	24 hour ^[2,3] Tcal \pm 1 °C	90 days Tcal \pm 5 °C	1 year Tcal \pm 1 °C	Temperature coefficient Tcal \pm 5 °C
DC voltage (with 34921A/22A/ 25A/31A/32A) ^[6]	100.0000 mV		0.0030 + 0.0035	0.0040 + 0.0040	0.0050 + 0.0040	0.0005 + 0.0005
	1.000000 V		0.0020 + 0.0006	0.0030 + 0.0007	0.0040 + 0.0007	0.0005 + 0.0001
	10.00000 V		0.0015 + 0.0004	0.0020 + 0.0005	0.0035 + 0.0005	0.0005 + 0.0001
	100.0000 V		0.0020 + 0.0006	0.0035 + 0.0006	0.0045 + 0.0006	0.0005 + 0.0001
	300.0000 V		0.0020 + 0.0020	0.0035 + 0.0030	0.0045 + 0.0030	0.0005 + 0.0003
Resistance ^[5]	100.0000 Ω	1mA	0.0030 + 0.0035	0.008 + 0.004	0.010 + 0.004	0.0006 + 0.0005
	1.000000 k Ω	1mA	0.0020 + 0.0006	0.008 + 0.001	0.010 + 0.001	0.0006 + 0.0001
	10.00000 k Ω	100 μ A	0.0020 + 0.0005	0.008 + 0.001	0.010 + 0.001	0.0006 + 0.0001
	100.0000 k Ω	10 μ A	0.0020 + 0.0005	0.008 + 0.001	0.010 + 0.001	0.0006 + 0.0001
	1.000000 M Ω	5.0 μ A	0.002 + 0.001	0.008 + 0.001	0.010 + 0.001	0.0010 + 0.0002
	10.00000 M Ω	500nA	0.015 + 0.001	0.020 + 0.001	0.040 + 0.001	0.0030 + 0.0004
	100.0000 M Ω	500nA/10M Ω	0.300 + 0.010	0.800 + 0.010	0.800 + 0.010	0.1500 + 0.0002
DC current (34921 only)	10.00000 mA	< 0.1 V burden	0.005 + 0.010	0.030 + 0.020	0.050 + 0.020	0.002 + 0.0020
	100.0000 mA	< 0.6V	0.010 + 0.004	0.030 + 0.005	0.050 + 0.005	0.002 + 0.0005
	1.000000 A	< 2V	0.050 + 0.006	0.080 + 0.010	0.100 + 0.010	0.005 + 0.0010

^[1] One hour warm-up and a fixed configuration with slow AC filter, sine wave input, and 6½ digits. Temperature within ± 5 °C of temperature at calibration (Tcal between 18-28 °C).

^[2] 90 minute warm-up and a fixed configuration and 6½ digits. Temperature within ± 1 °C of temperature at calibration (Tcal between 18-28 °C).

^[3] Relative to calibration standards

^[4] 20% over range on all ranges except 300VDC and AC ranges and 1 ADC and AC current ranges

^[5] For 4-wire ohms or 2-wire ohms using scaling to remove offset. Add 4 ohms additional error to 2-wire ohms function without scaling. 34923/24/25/33 have series resistance that may limit low 2-wire ohm measurements.

^[6] Add 50 μ V error for 34923/24/33.

AC Specifications ±(% of reading + % of range)

DMM accuracy ± (% of reading + % of range). Includes measurement error, switching error^[1], and transducer conversion error.

Function	Range ^[4]	Frequency	24 hour ^[2,3] Tcal ± 1 °C	90 days Tcal ± 5 °C	1 year Tcal ± 1 °C	Temperature coefficient Tcal ± 5 °C
True RMS AC voltage ^[5]	100.0000 mV to 100.0000 V	3Hz-5Hz	1.00 + 0.03	1.00 + 0.04	1.00 + 0.04	0.100 + 0.004
		5Hz-10Hz	0.35 + 0.03	0.35 + 0.04	0.35 + 0.04	0.035 + 0.004
		10Hz-20kHz	0.04 + 0.03	0.05 + 0.04	0.06 + 0.04	0.005 + 0.004
		20kHz-50kHz	0.10 + 0.05	0.11 + 0.05	0.12 + 0.05	0.011 + 0.005
		50kHz-100kHz	0.55 + 0.08	0.60 + 0.08	0.60 + 0.08	0.060 + 0.008
	300.0000 V	100kHz-300kHz ^[6]	4.00 + 0.50	4.00 + 0.50	4.00 + 0.50	0.20 + 0.02
		3Hz-5Hz	1.00 + 0.05	1.00 + 0.08	1.00 + 0.08	0.100 + 0.008
		5Hz-10Hz	0.35 + 0.05	0.35 + 0.08	0.35 + 0.08	0.035 + 0.008
		10Hz-20kHz	0.04 + 0.05	0.05 + 0.08	0.06 + 0.08	0.005 + 0.008
		20kHz-50kHz	0.10 + 0.10	0.11 + 0.12	0.12 + 0.12	0.011 + 0.012
		50kHz-100kHz	0.55 + 0.20	0.60 + 0.20	0.60 + 0.20	0.060 + 0.020
		100kHz-300kHz ^[6]	4.00 + 1.25	4.00 + 1.25	4.00 + 1.25	0.20 + 0.05
Frequency and period ^[7]	100mV to 300V	3Hz-5Hz	0.10	0.10	0.10	0.005
		5Hz-10Hz	0.05	0.05	0.05	0.005
		10Hz-40Hz	0.03	0.03	0.03	0.001
		40Hz-300kHz	0.006	0.01	0.01	0.001
True RMS AC current (34921A only)	10.00000 mA and ^[5] 1.0 A	3Hz-5Hz	1.00 + 0.04	1.00 + 0.04	1.00 + 0.04	0.100 + 0.006
		5Hz-10Hz	0.30 + 0.04	0.30 + 0.04	0.30 + 0.04	0.035 + 0.006
		10Hz-5kHz	0.10 + 0.04	0.10 + 0.04	0.10 + 0.04	0.015 + 0.006
	100.0000 mA ^[8]	3Hz-5Hz	1.00 + 0.5	1.00 + 0.5	1.00 + 0.5	0.100 + 0.006
		5Hz-10Hz	0.30 + 0.5	0.30 + 0.5	0.30 + 0.5	0.035 + 0.006
		10Hz-5kHz	0.10 + 0.5	0.10 + 0.5	0.10 + 0.5	0.015 + 0.006

^[1] One hour warm-up and a fixed configuration with slow AC filter, sine wave input, and 6½ digits. Temperature within ±5 °C of temperature at calibration (Tcal between 18-28 °C).

^[2] 90 minute warm-up and a fixed configuration and 6½ digits. Temperature within ±1 °C of temperature at calibration (Tcal between 18-28 °C).

^[3] Relative to calibration standards

^[4] 20% over range on all ranges except 300VDC and AC ranges and 1 ADC and AC current ranges

^[5] For sine wave input > 5% of range. For inputs from 1% to 5% of range and < 50 kHz add 0.1% of range additional error. For AC filter slow.

^[6] Typically 30% of reading error at 1 MHz, limited to 1 x 10⁸ volt-hertz

^[7] Input > 100 mV. For 10 mV inputs multiply % of reading error x 10. For 1 second aperture (6½ digits).

^[8] Specified only for inputs > 10 mA. For AC filter slow.

Additional Low Frequency Error for ACV, ACI (% of reading)

Frequency	AC Filter Slow	AC Filter Medium	AC Filter Fast
10 Hz – 20 Hz	0	0.74	–
20 Hz – 40 Hz	0	0.22	–
40 Hz – 100 Hz	0	0.06	0.73
100 Hz – 200 Hz	0	0.01	0.22
200 Hz – 1 kHz	0	0	0.18
>1 kHz	0	0	0

Additional Error for Frequency, Period (% of reading)

Frequency	Aperture (Digits)		
	1 second (6 digits)	0.1 seconds (5 digits)	0.01 seconds (4 digits)
3 Hz – 5 Hz	0	0.12	0.12
5 Hz – 10 Hz	0	0.17	0.17
10 Hz – 40 Hz	0	0.2	0.2
40 Hz – 100 Hz	0	0.06	0.21
100 Hz – 300 Hz	0	0.03	0.21
300 Hz – 1 kHz	0	0.01	0.07
>1 kHz	0	0	0.02

Temperature Specifications

Temperature	Type	1-year accuracy ^[1]	24 hour	Extended range ^[1]	1-year accuracy	Temp Coefficient
Thermocouple (34921A only, includes cold junction accuracy on terminal block)	B	1100 °C to 1820 °C	1.2 °C	400 °C to 1100 °C	1.8 °C	0.03 °C
	E	–150 °C to 1000 °C	1.0 °C	–200 °C to –150 °C	1.5 °C	0.03 °C
	J	–150 °C to 1200 °C	1.0 °C	–210 °C to –150 °C	1.2 °C	0.03 °C
	K	–100 °C to 1200 °C	1.0 °C	–200 °C to –100 °C	1.5 °C	0.03 °C
	N	–100 °C to 1300 °C	1.0 °C	–200 °C to –100 °C	1.5 °C	0.03 °C
	R	300 °C to 1760 °C	1.2 °C	–50 °C to 300 °C	1.8 °C	0.03 °C
	S	400 °C to 1760 °C	1.2 °C	–50 °C to 400 °C	1.8 °C	0.03 °C
	T	–100 °C to 400 °C	1.0 °C	–200 °C to –100 °C	1.5 °C	0.03 °C
RTD	R ₀ from 49 Ω to 2.1 kΩ	–200 °C to 600 °C	0.06 °C			0.003 °C
Thermistor	2.2k, 5k, 10k	–80 °C to 150 °C	0.08 °C			0.002 °C

^[1] For total measurement accuracy, add temperature probe error.

Typical System Speeds

Measurements made on a 3.2 GHz PC running VB6 in Windows XP Professional.

Single Channel Reading Time (in msec)	Direct Measurements – direct to I/O (includes switch, measure time, and I/O time)			Direct Measurement to Memory (GPIB)
	GPIB	USB 2.0	LAN (w/VXI 11)	Measurement into memory
Single Channel ^[1, 2]				
Single Channel, DCV	2.83 ms	3.14 ms	4.57 ms	1.9 ms
Single Channel, ACV	5.00 ms	5.35 ms	5.75 ms	4 ms
Single Channel, Ohms	2.91 ms	3.14 ms	4.65 ms	1.9 ms
Single Channel while changing scale (e.g. MEAS DCV 10 to MEAS DCV 1)	9.52 ms	10.64 ms	11.76 ms	8.4 ms
Single Channel while changing function (e.g. MEAS ACV to MEAS DCV)	128 ms	120 ms	120 ms	120 ms
Command Execution Time ^[3]				
34925A	Open or Close	0.7	0.9	1.6
	Read?	2.9	3.3	4.7
	Close/Read/Open	4.8	5.3	6.5
	Init/*WAI	1.9	2.1	3
	Close/Init/Open	3.7	4.1	4.7
34923A	Open or Close	0.9	1.2	1.8
	Read?	2.9	3.3	4.7
	Close/Read/Open	5.3	5.8	6.5
	Init/*WAI	1.9	2.1	3
	Close/Init/Open	4.2	4.7	5.2
34921A	Open or Close	4.7	5	5.3
	Read?	2.9	3.3	4.7
	Close/Read/Open	14	15	15
	Init/*WAI	1.9	2.1	3
	Close/Init/Open	12.4	14	14

^[1] Readings were made with minimum NPLC, delay 0, display off, autozero off.

^[2] All times include the issue of “READ?” and the retrieval of data.

^[3] CLOSE or OPEN bus transfer times allowed to overlap previous command. Command parse times overlap current activity until I/O latency dominant.

Single Channel Measurement Rates — DMM Reading Rates [1, 2]

Function	Resolution	Rdgs/s
DCV	4-1/2 digits (0.02 plc)	3000
	5-1/2 digits (1 plc)	59
	6-1/2 digits (10 plc)	6
2-wire Resistance	4-1/2 digits (0.02 plc)	2000
	5-1/2 digits (1 plc)	58
	6-1/2 digits (10 plc)	6
Thermocouple	(0.02 plc)	2000
	0.1°C (1 plc)	59
RTD/Thermistor	1°C (0.02 plc)	1900
	0.1°C (1 plc)	58
	0.01°C (10 plc)	6
ACV	6-1/2 fast (200 Hz)	350
	6-1/2 Med (20 Hz)	350
	6-1/2 slow (3 Hz)	300
Frequency, period	4-1/2 digits (10 ms)	70
	5-1/2 digits (100 ms)	9
	6-1/2 digits (1 s gate)	1

[1] Reading speeds for 60 Hz; autozero OFF

[2] For fixed function and range, readings to memory, scaling and alarms off, autozero OFF

Scanning Measurement Rates to Bus or Memory

Scanning Channels [1]	Direct Measurements – direct to I/O (includes switch, measure time, and I/O time)			Direct Measurement to Memory
	GPIB ch/sec	USB 2.0 ch/sec	LAN (w/VXI 11) ch/sec	Into memory ch/sec
Scanning DCV or Ohms				
34925A	920	860	980	1000
34923A/24A	588	572	605	625
34921A/22A	109	109	109	109
Scanning ACV [2]				
34925A	318	315	323	318
34923A/24A	260	260	260	260
34921A/22A	88	88	88	88
Scanning Temperature				
34921A	109	109	109	109
Scanning Digital in				
34950A	660	592	815	1038

[1] Speeds are for 4½ digits, delay 0, display off, autozero off. Scanning is within bank on the same module. Add 10 ms for between banks or modules.

[2] Add additional time for filter setting on ACV.

Data Out of Memory to LAN, USB, or GPIB

Data transfer rate with 1000 channel blocks.

	GPIB rdgs/sec	USB 2.0 rdgs/sec	LAN (w/VXI 11)^[1] rdgs/sec
Readings	2560	2400	3542
Readings with Timestamp	1304	1230	1826
Readings with all Format Options ON	980	926	1361

[1] LAN large block throughput rate is increased by approximately 30% using LAN sockets.

Internal DMM Measurement Characteristics

DC voltage	
Measurement method	Continuously integrating multi-slope III A-D converter
A-D linearity	0.0002% of reading + 0.0001% of range on 10 V range
Input resistance	
100 mV, 1 V, 10 V ranges	Selectable 10 M Ω or > 10,000 M Ω
100 V, 300 V ranges	10 M Ω \pm 1%
Input bias current	< 50 pA at 25 °C
Input Protection	300 V all ranges
True RMS AC voltage	
Measurement method	AC coupled True RMS - measures the AC component of the input with up to 300 VDC of bias on any range
Crest factor	Maximum of 5:1 at full scale
Additional crest factor errors (non-sinewave)	Crest factor 1-2 0.05% of reading Crest factor 2-3 0.15% of reading Crest factor 3-4 0.30% of reading Crest factor 4-5 0.40% of reading
AC Filter Bandwidth	
Slow	3 Hz – 300 kHz
Medium	20 Hz – 300 kHz
Fast	200 Hz – 300 kHz
Input impedance	1 M Ω \pm 2% in parallel with 150 pF
Input protection	300 Vrms all ranges
Resistance	
Measurement method	Selectable 4-wire or 2-wire ohms
Current source	Referenced to LO input
Offset compensation	Selectable on 100 Ω , 1 k Ω , and 10 k Ω ranges
Maximum lead resistance	10% of range per lead for 100 Ω and 1 k Ω ranges. 1 k Ω on all other ranges
Input protection	300 V on all ranges

Internal DMM Measurement Characteristics (continued)

Frequency and period	
Measurement method	Reciprocal counting technique
Voltage ranges	Same as AC voltage function
Gate time	1s, 100 ms, or 10 ms
Measurement time-out	Selectable 3 Hz, 20 Hz, 200 Hz LF limit
Measurement Consideration	All frequency counters are susceptible to error when measuring low-voltage, low-frequency signals. Shielding inputs from external noise pickup is critical for minimizing measurement errors.
DC Current	
Shunt resistance	5 Ω for 10 mA, 100 mA; 0.1 Ω for 1 A
Input protection	1A 250 V fuse on 34921A module
True RMS AC current	
Measurement method	Direct coupled to the fuse and shunt. AC coupled True RMS measurement (measures the ac component only).
Shunt resistance	5 Ω for 10 mA; 0.1 Ω for 100 mA, 1 A
Input protection	1A 250 V fuse on 34921A module
Thermocouple	
Conversion	ITS-90 software compensation
Reference junction type	Internal, fixed, or external
Open thermocouple check	Selectable per channel. Open > 5 k Ω
Thermistor	44004, 44007, 44006 series
RTD	$\alpha = 0.00385$ (DIN) and $\alpha = 0.00392$
Measurement noise rejection 60 (50) Hz ^[1]	
DC CMRR	140 dB
AC CMRR	70 dB
Integration time	Normal mode rejection ^[2]
200 plc/3.33 s (4 s)	105 dB ^[3]
100 plc/1.67 s (2 s)	100 dB ^[3]
20 plc/333 ms (400 ms)	95 dB ^[3]
10 plc/167 ms (200 ms)	90 dB ^[3]
2 plc/33.3 ms (40 ms)	85 dB
1 plc/16.7 ms (20 ms)	60 dB
< 1 plc	0 dB

^[1] For 1 k Ω unbalance in LO lead

^[2] For power line frequency $\pm 0.08\%$

^[3] For power line frequency $\pm 1\%$ use 75 dB or $\pm 2.5\%$ use 60 dB

Internal DMM Measurement Characteristics (continued)

DC Operating Characteristics ^[1]

Function	Digits ^[2]	Readings	Additional RMS Noise Error
DCV ^[4] , DCI, and Resistance ($\leq 10\text{ k}\Omega$)	6½	0.6 (0.5)	0% of range
	6½	6 (5)	0% of range
	5½	60 (50)	0.001% of range
	5½	300	0.001% of range ^[3]
	4½	600	0.01% of range ^[3]
Auto Zero OFF Operation	Following instrument warm-up at calibration temperature $\pm 1^\circ\text{C}$ and <10 minutes, add 0.0002% range additional error +5 μV . (For 300 VDC, instead of 0.0002% of range, use 0.00066% of range)		
Settling Considerations	Reading settling times are affected by source impedance, low dielectric absorption characteristics, and input signal changes.		

AC Operating Characteristics ^[5]

Function	Digits ^[6]	Readings/s	AC Filter
ACV, ACI	6½	7 s/reading	Slow (3 Hz)
	6½	1	Medium (20 Hz)
	5½	8 ^[7]	Fast (200 Hz)
	6½	10	Fast (200 Hz)
	6½	100 ^[8]	Fast (200 Hz)

^[1] Reading speeds for 60 Hz and (50 Hz) operation; autozero OFF

^[2] 6½ digits = 22 bits; 5½ digits = 18 bits; 4½ digits = 15 bits

^[3] Add 20 μV for DCV, 4 μA for DCI, or 20 $\text{m}\Omega$ for resistance.

^[4] For 300 VDC, multiply the additional noise error by 3.3.

^[5] Maximum reading rates for 0.01% of AC step additional error. Additional settling delay required when input DC level varies.

^[6] 6½ digits = 22 bits; 5½ digits = 18 bits; 4½ digits = 15 bits

^[7] For external trigger or remote operation using default settling delay (Delay Auto)

^[8] Maximum limit with default settling delays defeated

System Specifications and Characteristics

Scanning inputs	
Analog	34921A, 34922A, 34923A, 34924A, and 34925A multiplexer channels
Digital	34950A/52A digital in and totalize
Scan triggering	
Source	Interval, external, button press, software, or on monitor channel alarm
Scan count	1 to 50,000 or continuous
Scan interval	0 to 99 hours; 1 ms step size
Channel delay	0 to 60 seconds per channel; 1 ms step size
External trig delay	< 2 ms. With monitor on < 200 ms
External trig jitter	< 2 ms
Alarms	
Analog inputs	Hi, Lo, or Hi + Lo evaluated each scan
Digital inputs	34950A/52A digital in maskable pattern match or state change 34950A/52A frequency and totalize: Hi limit only
Monitor channel	Alarm evaluated each reading
Alarm outputs	4 TTL compatible Selectable TTL logic Hi or Lo on fail
Latency	5 ms (typical)
Memory	
Type	Volatile
Readings	500,000 with timestamp, readable during scan
States	5 instrument states with user label
Alarm queue	Up to 20 events with channel number, reading, and timestamp
System features	
Per-channel math min/max/average	Individual Mx+B scaling and calculated real time
Power fail recovery	Save switch states
Relay maintenance	Counts each relay closure and stores on module, user resettable
Real-time clock	Battery-backed, 20-year typical life

System Specifications and Characteristics (continued)

General specifications	
Power supply	Universal 100 V to 240 V $\pm 10\%$
Power line frequency	50 – 60 Hz $\pm 10\%$ automatically sensed
Power consumption	150 VA
Operating environment	Full accuracy for 0°C to 55°C Full accuracy to 80% R.H. at 40°C IEC 60664-1 pollution degree 1
Storage environment	–40°C to 70°C ^[1]
Mainframe dimensions	133H x 426W x 341D mm (5.25" x 16.8" x 14") Full rack, 3 units high
Mainframe weight	8.8 kg (19.6 lbs)
Module dimensions	280 x 170 x 27 mm (11" x 6.7" x 1")
Safety	Conforms to CSA, UL/IEC/EN 61010-1
EMC	Conforms to IEC/EN 61326-1, CISPR 11
Warranty	1 year

Software

Agilent IO Libraries Suite 14.0 or greater (E2094N) connectivity software included

Minimum system requirements (IO libraries and drivers)

PC hardware	Intel Pentium 100 MHz, 64 Mbyte RAM, 210 Mbyte disk space Display 800 x 600, 256 colors, CD-Rom drive
Operating system ^[2]	Windows®98 SE/NT/2000/XP
Computer interfaces	Standard LAN 10BaseT/100BaseTx Standard USB 2.0 IEEE 488.2 GPIB

Software driver support for programming languages

Software drivers	IVI-C and IVI COM for Windows NT/2000/XP LabVIEW
------------------	---

Compatible with:

Agilent VEE Pro, Agilent T&M Toolkit (requires Visual Studio.NET)

National Instruments Test Stand, Measurement Studio, LabWindows/CVI, LabVIEW, Switch Executive
Microsoft Visual Studio.NET, C/C++, Visual Basic 6

^[1] Storage at temperatures above 40°C will decrease battery life.

^[2] Load IO Libraries Version M for Windows NT support or version 14.0 for Windows 98 SE support.

Product Dimensions

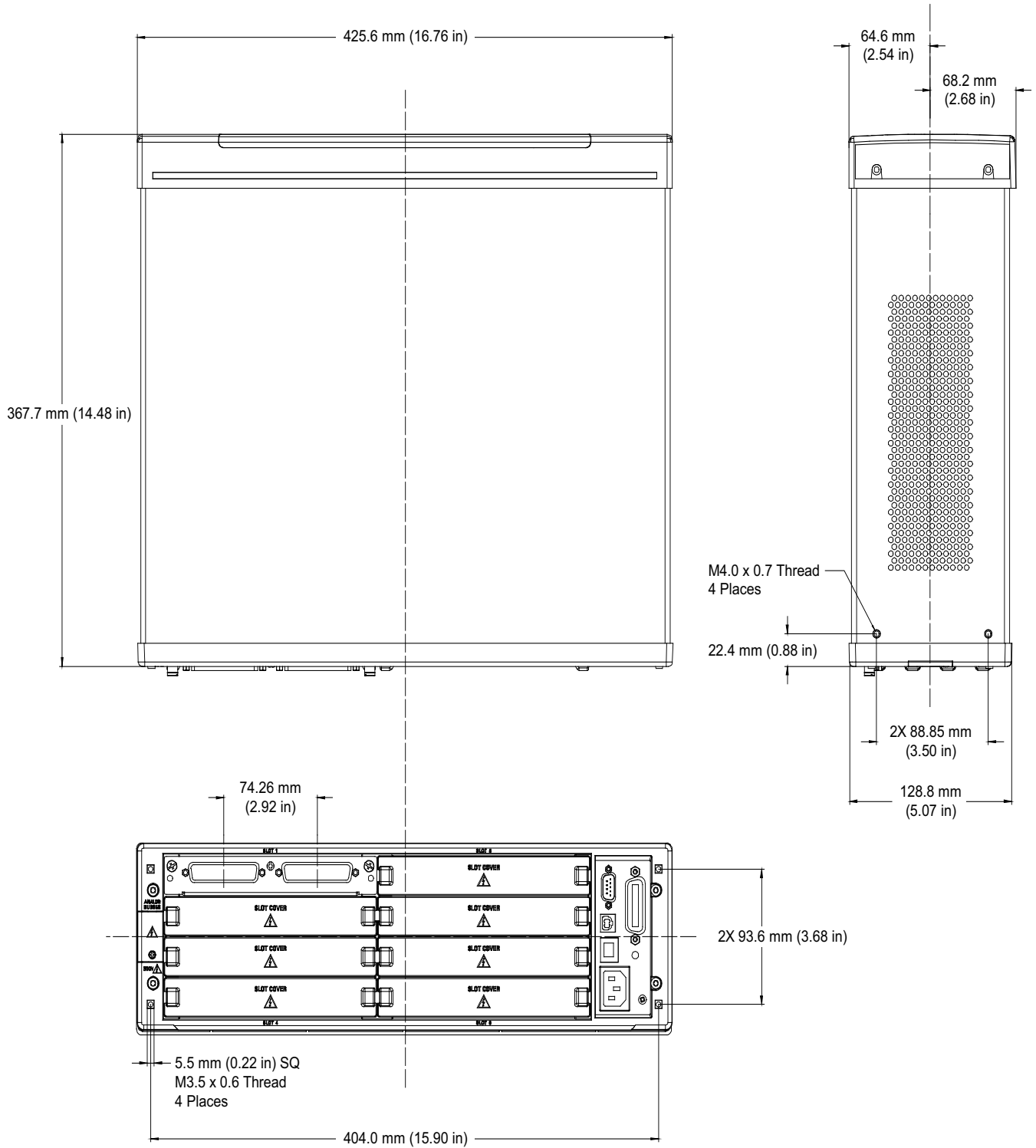

To Calculate Total DMM Measurement Error

Each specification includes correction factors which account for errors present due to operational limitations of the optional internal DMM. This section explains these errors and shows how to apply them to your measurements.

Refer to [“Interpreting Internal DMM Specifications”](#) on page 39, to get a better understanding of the terminology used and to help you interpret the internal DMM’s specifications.

The internal DMM’s accuracy specifications are expressed in the form: (*% of reading + % of range*).

In addition to the reading error and range error, you may need to add additional errors for certain operating conditions. Check the list below to make sure you include all measurement errors for a given function. Also, make sure you apply the conditions as described in the footnotes on the specification pages.

- If you are operating the internal DMM outside the $23\text{ }^{\circ}\text{C} \pm 5\text{ }^{\circ}\text{C}$ temperature range specified, apply an additional temperature coefficient error.
- For dc voltage, dc current, and resistance measurements, you may need to apply an additional reading speed error.
- For ac voltage and ac current measurements, you may need to apply an additional low frequency error or crest factor error.

Understanding the “% of reading” Error The reading error compensates for inaccuracies that result from the function and range you select, as well as the input signal level. The reading error varies according to the input level on the selected range. This error is expressed in percent of reading. The following table shows the reading error applied to the internal DMM’s 24-hour dc voltage specification.

Range	Input Level	Reading Error (% of reading)	Reading Error Voltage
10 Vdc	10 Vdc	0.0015	$\leq 150\text{ }\mu\text{V}$
10 Vdc	1 Vdc	0.0015	$\leq 15\text{ }\mu\text{V}$
10 Vdc	0.1 Vdc	0.0015	$\leq 1.5\text{ }\mu\text{V}$

Understanding the “% of range“ Error The range error compensates for inaccuracies that result from the function and range you select. The range error contributes a constant error, expressed as a percent of range, independent of the input signal level. The following table shows the range error applied to the DMM’s 24-hour dc voltage specification.

Range	Input Level	Range Error (% of range)	Range Error voltage
10 Vdc	10 Vdc	0.0004	≤40 μV
10 Vdc	1 Vdc	0.0004	≤40 μV
10 Vdc	0.1 Vdc	0.0004	≤40 μV

Total Measurement Error To compute the total measurement error, add the reading error and range error. You can then convert the total measurement error to a “percent of input” error or a “ppm (part-per-million) of input” error as shown below.

$$\% \text{ of input error} = \frac{\text{Total Measurement Error}}{\text{Input Signal Level}} \times 100$$

$$\text{ppm of input error} = \frac{\text{Total Measurement Error}}{\text{Input Signal Level}} \times 1,000,000$$

Example: Computing Total Measurement Error

Assume that a 5 Vdc signal is input to the DMM on the 10 Vdc range. To compute the total measurement error using the 90-day accuracy specification of ±(0.0020% of reading + 0.0005% of range).

$$\begin{aligned} \text{Reading Error} &= 0.0020\% \times 5 \text{ Vdc} = 100 \mu\text{V} \\ \text{Range error} &= 0.0005\% \times 10 \text{ Vdc} = 50 \mu\text{V} \\ \text{Total Error} &= 100 \mu\text{V} + 50 \mu\text{V} = \pm 150 \mu\text{V} \\ &= \pm 0.0030\% \text{ of } 5 \text{ Vdc} \\ &= \pm 30 \text{ ppm of } 5 \text{ Vdc} \end{aligned}$$

Interpreting Internal DMM Specifications

This section is provided to give you a better understanding of the terminology used and will help you interpret the internal DMM's specifications.

Number of Digits and Overrange The “number of digits” specification is the most fundamental, and sometimes, the most confusing characteristic of an instrument. The number of digits is equal to the maximum number of “9’s” the instrument can measure or display. This indicates the number of full digits. Most instruments have the ability to overrange and add a partial or “½” digit.

For example, the internal DMM can measure 9.99999 Vdc on the 10 V range. This represents six full digits of resolution. The internal DMM can also overrange on the 10 V range and measure up to a maximum of 12.00000 Vdc. This corresponds to a 6½-digit measurement with 20% overrange capability.

Sensitivity Sensitivity is the minimum level that the instrument can detect for a given measurement. Sensitivity defines the ability of the instrument to respond to small changes in the input level. For example, suppose you are monitoring a 1 mVdc signal and you want to adjust the level to within $\pm 1 \mu\text{V}$. To be able to respond to an adjustment this small, this measurement would require an instrument with a sensitivity of at least $1 \mu\text{V}$. You could use a 6½-digit instrument if it has a 1 Vdc or smaller range. You could also use a 4½-digit instrument with a 10 mVdc range.

For ac voltage and ac current measurements, note that the smallest value that can be measured is different from the sensitivity. For the internal DMM, these functions are specified to measure down to 1% of the selected range. For example, the internal DMM can measure down to 1 mV on the 100 mV range.

Resolution Resolution is the numeric ratio of the maximum displayed value divided by the minimum displayed value on a selected range. Resolution is often expressed in percent, parts-per-million (ppm), counts, or bits. For example, a 6½-digit instrument with 20% overrange capability can display a measurement with up to 1,200,000 counts of resolution. This corresponds to about 0.0001% (1 ppm) of full scale, or 21 bits including the sign bit. All four specifications are equivalent.

Accuracy Accuracy is a measure of the “exactness” to which the internal DMM’s measurement uncertainty can be determined relative to the calibration reference used. Absolute accuracy includes the Internal DMM’s relative accuracy specification plus the known error of the calibration reference relative to national standards (such as the U.S. National Institute of Standards and Technology). To be meaningful, the accuracy specifications must be accompanied with the conditions under which they are valid. These conditions should include temperature, humidity, and time.

There is no standard convention among instrument manufacturers for the confidence limits at which specifications are set. The table below shows the probability of non-conformance for each specification with the given assumptions.

Specification Criteria	Probability of Failure
Mean \pm 2 sigma	4.5%
Mean \pm 3 sigma	0.3%

Variations in performance from reading to reading, and instrument to instrument, decrease for increasing number of sigma for a given specification. This means that you can achieve greater actual measurement precision for a specific accuracy specification number.

The internal DDMM is designed and tested to meet performance better than mean \pm 3 sigma of the published accuracy specifications.

24-Hour Accuracy The 24-hour accuracy specification indicates the internal DMM’s relative accuracy over its full measurement range for short time intervals and within a stable environment. Short-term accuracy is usually specified for a 24-hour period and for a \pm 1°C temperature range.

90-Day and 1-Year Accuracy These long-term accuracy specifications are valid for a 23°C \pm 5°C temperature range. These specifications include the initial calibration errors plus the internal DMM’s long-term drift errors.

Temperature Coefficients Accuracy is usually specified for a 23°C \pm 5°C temperature range. This is a common temperature range for many operating environments. You must add additional temperature coefficient errors to the accuracy specification if you are operating the instrument outside a 23°C \pm 5°C temperature range (the specification is per °C).

Configuring for Highest Accuracy Measurements

The measurement configurations shown below assume that the internal DMM is in its Factory Reset state. It is also assumed that manual ranging is enabled to ensure proper full scale range selection.

DC Voltage, DC Current, and Resistance Measurements:

- Set the resolution to 6 digits (you can use the 6 digits slow mode for further noise reduction).
- Set the input resistance to greater than 10 G Ω (for the 100 mV, 1 V, and 10 V ranges) for the best dc voltage accuracy.
- Use 4-wire ohms and enable offset compensation for the best resistance accuracy.

AC Voltage and AC Current Measurements:

Set the resolution to 6 digits.

- Select the slow ac filter (3 Hz to 300 kHz).

Frequency and Period Measurements:

Set the resolution to 6 digits.

2 Specifications

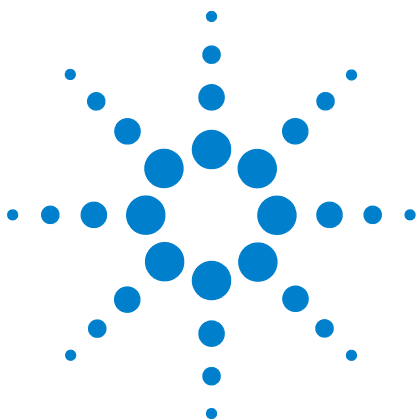

3 Calibration Procedures

Agilent Technologies Calibration Services	44
Calibration Interval	44
Adjustment is Recommended	44
Time Required for Calibration	45
Automating Calibration Procedures	45
Recommended Test Equipment	46
Calibration Security	47
Calibration Message	48
Calibration Count	48
Calibration Process	49
Aborting a Calibration in Progress	49
Performance Verification Tests	50
Input Connections	52
DMM Test Considerations	53
Internal DMM Verification Tests	53
Optional AC Performance Verification Tests	59
Internal DMM Adjustments	60
Gain Adjustment	61
Plug-in Module Test Considerations	65
34951A 4-Ch Isolated DAC Module	66
34952A Multifunction Module	71
Relay Plug-in Modules	73
Thermocouple Reference Junction 34921A (Optional)	75



Calibration Procedures

This manual contains procedures for verification of the instrument's performance and adjustment (calibration).

Closed-Case Electronic Calibration The instrument features closed-case electronic calibration. No internal mechanical adjustments are required. The instrument calculates correction factors based upon the input reference value you set. The new correction factors are stored in non-volatile memory until the next calibration adjustment is performed. Non-volatile EEPROM calibration memory does not change when power has been off or after a remote interface reset.

Agilent Technologies Calibration Services

Agilent Technologies offers calibration services at competitive prices. When your instrument is due for calibration, contact your local Agilent Service Center for recalibration. See ["Types of Service Available"](#) on page 6 for information on contacting Agilent.

Calibration Interval

The instrument should be calibrated on a regular interval determined by the measurement accuracy requirements of your application.

A 1-year interval is adequate for most applications. Accuracy specifications are warranted only if adjustment is made at regular calibration intervals. Accuracy specifications are not warranted beyond the 1-year calibration interval. Agilent does not recommend extending calibration intervals beyond 2 years for any application.

Adjustment is Recommended

Specifications are only guaranteed within the period stated from the last adjustment. Whatever calibration interval you select, Agilent recommends that complete re-adjustment should always be performed at the calibration interval. This will assure that the 34980A will remain within specification for the next calibration interval. This criteria for re-adjustment provides the best long-term stability.

Performance data measured during Performance Verification Tests does not guarantee the instrument will remain within these limits unless the adjustments are performed.

Use the Calibration Count feature (see [page 48](#)) to verify that all adjustments have been performed.

Time Required for Calibration

The 34980A can be automatically calibrated under computer control. With computer control you can perform the complete calibration procedure and performance verification tests in less than 30 minutes once the instrument is warmed-up (see [“DMM Test Considerations”](#) on page 53).

Automating Calibration Procedures

You can automate the complete verification and adjustment procedures outlined in this manual. You can program the instrument configurations specified for each test over the remote interface. You can then enter readback verification data into a test program and compare the results to the appropriate test limit values.

You must adjust the instrument using the remote interface. Adjustment cannot be performed from the local front-panel. The instrument must be unsecured prior to initiating the calibration procedure (see [“Calibration Security”](#) on page 47).

For further information on programming the instrument, see Chapter 2 in the *34980A User's Guide*.

For information about errors that may occur during the calibration procedure, see [“Calibration Errors”](#) on page 86.

Recommended Test Equipment

The test equipment recommended for the performance verification and adjustment procedures is listed below. If the exact instrument is not available, substitute calibration standards of equivalent accuracy.

A suggested alternate method would be to use the Agilent 3458A 8½-digit Digital Multimeter to measure less accurate yet stable sources. The output value measured from the source can be entered into the instrument as the target calibration value.

Application	Recommended Equipment	Accuracy Requirements
Zero Calibration	None	4 -terminal all copper short
DC Voltage	Fluke 5700A	<1/5 instrument 24 hour spec
DC Current	Fluke 5700A/ 5725A	<1/5 instrument 24 hour spec
Resistance	Fluke 5700A	<1/5 instrument 24 hour spec
AC Voltage	Fluke 5700A/ 5725A	<1/5 instrument 24 hour spec
AC Current	Fluke 5700A/ 5725A	<1/5 instrument 24 hour spec
Frequency	Agilent 33220A	<1/5 instrument 24 hour spec
Analog Output 34951A	Internal DMM	<1/5 instrument 24 hour spec
Analog Output 34952A	Internal DMM	<1/5 instrument 24 hour spec
Thermocouple Reference Junction 34921A with 34921T Only	J Type Calibrated Thermocouple Triple Point Cell	$\pm 0.1 \times ^\circ\text{C}$
Relay contact resistance ^[1] All switch modules	Agilent Y1131A	$\pm 0.001\Omega$ resolution

[1] Optional test if not using relay cycle count.

Calibration Security

This feature allows you to enter a security code to prevent accidental or unauthorized adjustments of the instrument. When you first receive your instrument, it is secured. Before you can adjust the instrument, you must unsecure it by entering the correct security code.

NOTE

If you forget your security code, you can disable the security feature by following the procedure below.

- The security code is set to AT34980 when the instrument is shipped from the factory. The security code is stored in non-volatile memory, and does not change when power has been off, after a Factory Reset (*RST command), or after an Instrument Preset (SYSTEM:PRESet command).
- The security code may contain up to 12 alphanumeric characters. The first character must be a letter, but the remaining characters can be letters, numbers, or an underscore (_). You do not have to use all 12 characters but the first character must always be a letter.
- The 34951A 4 Channel DAC has two modes of adjustment, based upon the setting of the calibration security feature. Additional details are described in ["34951A 4-Ch Isolated DAC Module"](#) on page 66.

Use the CALibration:SECure:STATe <mode>, <code> command to secure or unsecure the instrument. Refer to the *34980A Programmer's Reference Help File* for complete information.

To Unsecure the Instrument Without the Security Code To unsecure the instrument without the correct security code, follow the steps below.

- 1 Turn off the instrument.
- 2 Press and hold the DMM (Measure) key and CANCEL key and turn on the unit. You can release the keys when the unit has completed the power on sequence.
- 3 Send the CALibration:SECure:STATe OFF, <code> command to the instrument. You may use any valid sequence of characters for the <code> value.
- 4 The unit is now unsecured for calibration.
- 5 Enter a new security code when calibration is complete. Be sure to remember the new security code.

Calibration Message

The instrument allows you to store a message in calibration memory. You may store a calibration message for the mainframe, the DMM, the 34951A 4-Ch Isolated DAC Module, and 34952A Multifunction Module. For example, you can store such information as the date when the last calibration was performed, the date when the next calibration is due, the instrument's serial number, or even the name and phone number of the person to contact for a new calibration.

- You can record a calibration message only from the remote interface and only when the instrument is unsecured. You can read the calibration message whether the instrument is secured or unsecured.
- The calibration message may contain up to 40 characters.
- Remote Interface Commands:

```
CALibration:STRing <string>,{<slot>|MAINframe|DMM}  
CALibration:STRing? {<slot>|MAINframe|DMM}
```

Calibration Count

You can query the mainframe, the DMM, the 34951A 4-Ch Isolated DAC Module, and 34952A Multifunction Module to determine how many calibrations have been performed. Note that your instrument was calibrated before it left the factory. When you receive your instrument, be sure to read the count to determine its initial value.

- The calibration count increments up to a maximum of 2^{32} after which it rolls over to "0". Since the value increments by one for each calibration point, a complete calibration may increase the value by many counts.
- The calibration count is also incremented with calibrations of the 34951A 4-Ch DAC and DAC channels on the 34952A multifunction module.
- Remote Interface Command:

```
CALibration:COUNT? {<slot>|MAINframe|DMM}
```

Calibration Process

The following general procedure is the recommended method to complete a full instrument calibration.

- 1 Read “[DMM Test Considerations](#)” on page 53 and “[Plug-in Module Test Considerations](#)” on page 65.
- 2 Perform the verification tests to characterize the instrument (incoming data).
- 3 Unsecure the instrument for calibration (“[Calibration Security](#)” on page 47).
- 4 Perform the DMM adjustment procedures (“[Internal DMM Adjustments](#)” on page 60).
- 5 Perform the DAC adjustment procedures if either the 34951A (“[34951A 4-Ch Isolated DAC Module](#)” on page 66) or 34952A (“[34952A Multifunction Module](#)” on page 71) is installed.
- 6 Secure the instrument against calibration.
- 7 Note the new security code and calibration count in the instrument’s maintenance records.

NOTE

The 34951A 4-Ch Isolated DAC is intended to be adjusted frequently to compensate for changes in the module’s environment. These adjustments can be made either volatile or non-volatile. See [page 66](#) for details.

Aborting a Calibration in Progress

Sometimes it may be necessary to abort a calibration after the procedure has already been initiated. You can abort a calibration at any time on any module by turning off the power. You can abort a calibration on the internal DMM or the 34951A 4-Ch Isolated DAC by issuing a remote interface device clear message. You can abort a calibration on the 34952A Multifunction Module by sending the `CALibration:ABORT` command.

CAUTION

If you abort a calibration in progress when the instrument is attempting to write new calibration constants to EEPROM, you may lose all calibration constants for the function. Typically, upon re-applying power, the instrument will report error **705 Cal:Aborted**. You may also generate errors 740 through 746. If this occurs, you should not use the instrument until a complete re-adjustment has been performed. For a list of calibration error numbers, see [page 86](#).

Performance Verification Tests

Use the Performance verification Tests to verify the measurement performance of the instrument. The performance verification tests use the instrument's specifications listed in *Chapter 2 Specifications* in this manual.

You can perform four different levels of performance verification tests:

- **Self-Test** A series of internal verification tests that give a high confidence that the instrument is operational.
- **Quick Verification** A combination of the internal self-tests and selected verification tests.
- **Performance Verification Tests** An extensive set of tests that are recommended as an acceptance test when you first receive the instrument or after performing adjustments.
- **Optional Verification Tests** Tests not performed with every calibration. Perform these tests to verify additional specifications or functions of the instrument.

Self-Test

A brief power-on self-test occurs automatically whenever you turn on the instrument. This limited test assures that the instrument is capable of operation and also checks the plug-in modules for basic operation.

- During the self-test all display segments and annunciators are lit.
- If the self-test fails, the ERROR annunciator turns on. Read any errors using the front panel View menu, or use the `SYSTEM:ERROR?` command query from the remote interface. If repair is required, contact an Agilent Service Center.
- If all tests pass, you have a high confidence (~90%) that the instrument is operational.
- You can initiate a more complete self test by sending the `*TST?` command to the instrument. This command returns a "+0" if all the self-tests pass, or a "+1" if a failure occurred. Depending upon the number and type of modules installed, this command may take up to 2½ minutes to complete. You may need to set an appropriate interface time-out value.

Quick Performance Check

The quick performance check is a combination of internal self-test and an abbreviated performance test (specified by the letter **Q** in the performance verification tests). This test provides a simple method to achieve high confidence in the instrument's ability to functionally operate and meet specifications. These tests represent the absolute minimum set of performance checks recommended following any service activity. Auditing the instrument's performance for the quick check points (designated by a **Q**) verifies performance for "normal" accuracy drift mechanisms. This test does not check for abnormal component failures.

To perform the quick performance check, do the following:

- Perform a self-test as described on [page 50](#).
- Perform only the performance verification tests indicated with the letter **Q**.

If the instrument fails the quick performance check, adjustment or repair is required.

Performance Verification Tests

The performance verification tests are recommended as acceptance tests when you first receive the instrument. The acceptance test results should be compared against the 90 day test limits. You should use the 24-hour test limits only for verification within 24 hours after performing the adjustment procedure. After acceptance, you should repeat the performance verification tests at every calibration interval.

If the instrument fails performance verification, adjustment or repair is required.

Adjustment is recommended at every calibration interval. If adjustment is not made, you must guard band, using no more than 80% of the specifications, as the verification limits.

Internal DMM

Input Connections

Test connections to the internal DMM are best accomplished using the rear panel Analog Bus connector (ABus). You may need to remove the cover for access to this connector. A test fixture can be constructed using a standard DB9 male connector, some shielded twisted pair Teflon[®] insulated cables, and appropriate connectors for the calibrator output you are using.

You may also use one of the multiplexer modules to connect the calibrator output to the DMM. If you use a multiplexer module, you must take into account any additional relay contacts and resistances in the measurement path. To do this, use the switch/measure model to set up the DMM and switches, not the scan model. For example, send:

```
conf:fres 100;:rout:clos (@1001,1021,1911,1922)
read? (should return something close to zero)
cal:val 0
cal?
```

In this manual, the direct ABus connection is the one described. Connections for the ABus connector are shown below.

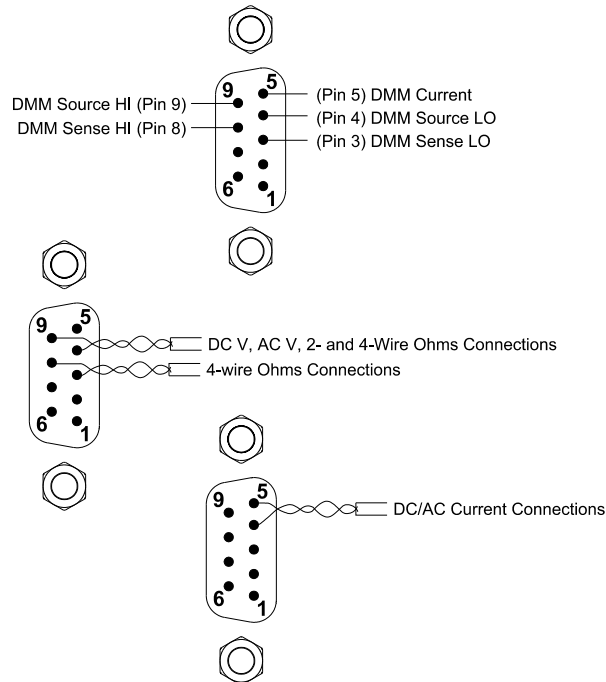

NOTE

Use shielded twisted pair Teflon[®] insulated cables to reduce settling and noise errors. Connect the shield to the source LO output.

Teflon[®] is a registered trademark of E.I. du Pont de Nemours and Company.

DMM Test Considerations

Errors may be induced by ac signals present on the input leads during a self-test. Long test leads can also act as an antenna causing pick-up of ac signals.

For optimum performance, all procedures should comply with the following recommendations:

- Assure that the calibration ambient temperature is stable and between 18 °C and 28 °C. Ideally the calibration should be performed at 23 °C ±1 °C.
- Assure ambient relative humidity is less than 80%.
- Allow a 1.5-hour warm-up period with a copper short connected. The connections are shown in the figure on [page 52](#).
- Use shielded twisted pair Teflon® insulated cables to reduce settling and noise errors. Keep the input cables as short as possible.
- Connect the input cable shield to the source LO output. Except where noted in the procedures, connect the calibrator LO source to earth ground.
- Either remove all modules from the mainframe, or reset the modules to ensure no module is connected to the backplane ABUS.

Because the instrument is capable of making highly accurate measurements, you must take special care to ensure that the calibration standards and test procedures used do not introduce additional errors. Ideally, the standards used to verify and adjust the instrument should be an order of magnitude more accurate than each instrument range full scale error specification.

For the dc voltage, dc current, and resistance gain verification measurements, you should take care to ensure the calibrator's "0" output is correct. If necessary, the measurements can be referenced to the calibrator's "0" output using $Mx + B$ scaling (see Chapter 2 in the 34980A User's Guide). You will need to set the offset for each range of the measuring function being verified.

Internal DMM Verification Tests

Zero Offset Verification

This procedure is used to check the zero offset performance of the internal DMM. Verification checks are only performed for those functions and ranges with unique offset calibration constants. Measurements are checked for each function and range as described in the procedure on the next page.

Zero Offset Verification Procedure

- 1 Make sure you have read “DMM Test Considerations” on page 53.
- 2 Short all the inputs on the input test connector (see page 52).
Leave the Current input open. Connect the shorts as close to the input connector as possible.
- 3 Select each function and range in the order shown in the table below. Make a measurement and return the result. Compare measurement results to the appropriate test limits shown in the table.

Input	Function ^[1]	Range	Quick Check	Error from Nominal		
				24 hour	90 day	1 year
Open	DC Current	10 mA		± 1 µA	± 2 µA	± 2 µA
Open		100 mA	Q	± 4 µA	± 5 µA	± 5 µA
Open		1 A		± 60 µA	± 100 µA	± 100 µA
Short	DC Volts	100 mV		± 3.5 µV	± 4 µV	± 4 µV
Short		1 V		± 6 µV	± 7 µV	± 7 µV
Short		10 V	Q	± 40 µV	± 50 µV	± 50 µV
Short		100 V		± 600 µV	± 600 µV	± 600 µV
Short		300 V		± 6 mV	± 9 mV	± 9 mV
Short	2-Wire Ohms ^[2] and 4-Wire Ohms	100 Ω		± 3.5 mΩ	± 4 mΩ	± 4 mΩ
Short		1 kΩ		± 6 mΩ	± 10 mΩ	± 10 mΩ
Short		10 kΩ	Q	± 50 mΩ	± 100 mΩ	± 100 mΩ
Short		100 kΩ		± 500 mΩ	± 1 Ω	± 1 Ω
Short		1 MΩ		± 10 Ω	± 10 Ω	± 10 Ω
Short		10 MΩ		± 100 Ω	± 100 Ω	± 100 Ω
Short		100 MΩ		± 10 kΩ	± 10 kΩ	± 10 kΩ

[1] Select 6½ digit resolution.

[2] For 2-wire ohms using a multiplexer for the input connections, an additional 4 Ω of error for the relay contacts must be added.

Q: Quick performance verification test points.

NOTE

Zero offset calibration using a multifunction calibrator is NOT recommended. The calibrator and cabling offset can be large and unstable causing poor offset calibration of the internal DMM.

Gain Verification

This procedure is used to check the “full scale” reading accuracy of the internal DMM. Verification checks are performed only for those functions and ranges with unique gain calibration constants.

DC VOLTS, Resistance, and DC CURRENT Gain Verification Test

- 1 Make sure you have read “[DMM Test Considerations](#)” on page 53.
- 2 Select each function and range in the order shown below. Provide the input shown in the table below.
- 3 Make a measurement and return the result. Compare measurement results to the appropriate test limits shown in the table. (Be certain to allow for appropriate source settling when using the Fluke 5700A.)

Input	Function ^[1]	Range	Quick Check	Error from Nominal		
				24 hour	90 day	1 year
100 mV	DC Volts	100 mV		± 6.5 µV	± 8 µV	± 9 µV
1 V		1 V		± 26 µV	± 37 µV	± 47 µV
10 V		10 V	Q	± 190 µV	± 250 µV	± 400 µV
100 V		100 V	Q	± 2.6 mV	± 4.1 mV	± 5.1 mV
300 V		300 V		± 12 mV	± 19.5 mV	± 22.5 mV
100 Ω	2-Wire Ohms ^[2] and 4-Wire Ohms	100 Ω		± 6.5 mΩ	± 12 mΩ	± 14 mΩ
1 kΩ		1 kΩ	Q	± 26 mΩ	± 90 mΩ	± 110 mΩ
10 kΩ		10 kΩ		± 250 mΩ	± 900 mΩ	± 1.1 Ω
100 kΩ		100 kΩ		± 2.5 Ω	± 9 Ω	± 11 Ω
1 MΩ		1 MΩ		± 30 Ω	± 90 Ω	± 110 Ω
10 MΩ		10 MΩ	Q	± 1.6 kΩ	± 2.1 kΩ	± 4.1 kΩ
100 MΩ ^[3]		100 MΩ		± 310 kΩ	± 810 kΩ	± 810 kΩ
10 mA	DC Current	10 mA		± 1.5 µA	± 5 µA	± 7 µA
100 mA		100 mA	Q	± 14 µA	± 35 µA	± 55 µA
1 A		1 A		± 560 µA	± 900 µA	± 1.1 mA

[1] Select 6 ½ digit resolution.

[2] The 2-wire ohms resistance verification test is optional (see “[Gain Adjustment Considerations](#)” on page 61). For 2-wire ohms using a multiplexer for the input connections, an additional 4 Ω of error for the relay contacts must be added. Add a 1-second channel delay when using Fluke 5700 in 2-wire compensated mode. This avoids response time issues with 2-wire compensation when 34980A’s current source contains a pulse.

[3] Verify only, no adjustment required.

Q: Quick performance verification test points.

AC VOLTS Gain Verification Test

Configuration: AC Volts
 CONFigure[:VOLTage]:AC
 LF 3 HZ:SLOW
 [SENSe:]VOLTage:AC:BANDwidth 3

- 1 Make sure you have read “DMM Test Considerations” on page 53.
- 2 Set the AC VOLTS function and the 3 Hz input filter. With the slow filter selected, each measurement takes 7 seconds to complete.
- 3 Select each range in the order shown below. Provide the indicated input voltage and frequency. Compare measurement results to the appropriate test limits shown in the table. (Be certain to allow for appropriate source settling.)

Input			Quick Check	Error from Nominal		
Vrms	Frequency	Range		24 hour	90 day	1 year
100 mV	1 kHz	100 mV		± 70 µV	± 90 µV	± 100 µV
100 mV	50 kHz		Q	± 150 µV	± 160 µV	± 170 µV
1 V	1 kHz	1		± 700 µV	± 900 µV	± 1 mV
1 V	50 kHz			± 1.5 mV	± 1.6 mV	± 1.7 mV
10 V	1 kHz	10 V		± 7 mV	± 9 mV	± 10 mV
10 V	50 kHz		Q	± 15 mV	± 16 mV	± 17 mV
10 V	10 Hz			± 7 mV	± 9 mV	± 10 mV
10 mV ^[1]	1 kHz	100 mV		± 34 µV	± 45 µV	± 46 µV
100 V	1 kHz	100 V	Q	± 70 mV	± 90 mV	± 100 mV
100 V	50 kHz			± 150 mV	± 160 mV	± 170 mV
300 V	1 kHz	300 V		± 270 mV	± 390 mV	± 420 mV
300 V ^[2]	50 kHz			± 600 mV	± 690 mV	± 720 mV

[1] For this test, isolate the calibrator’s output from earth ground to prevent ground noise affecting the reading.

[2] Some calibrators may have difficulty driving the internal DMM and cable load at this V-Hz output. Use short, low capacitance cable to reduce calibration loading. Verification can be performed at >195 Vrms. New test limits can be computed from the accuracy specification shown in the data sheet for the actual test conditions used.

Q: Quick performance verification test points.

NOTE

The 50 kHz ac voltage test points may fail performance verification if the DMM internal shields have been removed and reinstalled. See “Gain Adjustment” on page 61 for further information on how to recalibrate the ac voltage function.

AC CURRENT Gain Verification Test

Configuration: AC Current
 CONFigure:CURRent:AC
 LF 3 HZ:SLOW
 [SENSE:]CURRent:AC:BANDwidth 3

- 1 Make sure you have read “DMM Test Considerations” on page 53.
- 2 Set the AC CURRENT function and the 3 Hz input filter. With the slow filter selected, each measurement takes 7 seconds to complete.
- 3 Select each range in the order shown below. Provide the input current and frequency indicated. Compare measurement results to the appropriate test limits shown in the table. (Be certain to allow for appropriate source settling.)

Input			Quick Check	Error from Nominal		
Current	Frequency	Range		24 hour	90 day	1 year
10 mA ^[1]	1 kHz	10 mA		± 14 µA	± 14 µA	± 14 µA
100 mA ^[1]	1 kHz	100 mA	Q	± 600 µA	± 600 µA	± 600 µA
10 mA	1 kHz	1 A		± 1.41 mA	± 1.41 mA	± 1.41 mA
1A ^[1]	1 kHz	1 A		± 1.4 mA	± 1.4 mA	± 1.4 mA

[1] Verify only, no adjustment.
Q: Quick performance verification test points.

Frequency Gain Verification Test

Configuration: Frequency
 6½ digits
 [SENSe:]FREQUency:APERture 1

- 1 Make sure you have read “DMM Test Considerations” on page 53.
- 2 Select the FREQUENCY function and set 6½ digits.
- 3 Select each range in the order shown below. Provide the input voltage and frequency indicated. Compare measurement results to the appropriate test limits shown in the table. (Be certain to allow for appropriate source settling.)

Input			Quick Check	Error from Nominal		
Voltage	Frequency	Range		24 hour	90 day	1 year
10 mV ^[1]	100 Hz	100 mV		± 0.06 Hz	± 0.1 Hz	± 0.1 Hz
1 V	100 kHz	1 V	Q	± 6 Hz	± 10 Hz	± 10 Hz

[1] Verify only, No adjustment. For this test, isolate the calibrator’s output from earth ground.

Q: Quick performance verification test points.

Optional AC Performance Verification Tests

These tests are *not* intended to be performed with every calibration. They are provided as an aid for verifying additional instrument specifications. There are no adjustments for these tests; they are provided for performance verification only.

```
Configuration: AC Volts
CONFigure[:VOLTage]:AC
LF 3 HZ:SLOW
[SENSe:]VOLTage:AC:BANDwidth 3
```

- 1 Make sure you have read “DMM Test Considerations” on page 53.
- 2 Select the AC Volts function and the 3 Hz filter.
- 3 Select each range in the order shown below. Provide the input voltage and frequency indicated. Compare measurement results to the appropriate test limits shown in the table below. (Be certain to allow for appropriate source settling.)

Input			Error from Nominal		
Voltage	Frequenc y	Range	24 hour	90 day	1 year
1 V	20 Hz	1 V	± 700 µV	± 900 µV	± 1 mV
1 V	20 kHz	1 V	± 700 µV	± 900 µV	± 1 mV
1 V	100 kHz	1 V	± 6.3 mV	± 6.8 mV	± 6.8 mV
1 V	300 kHz	1 V	± 45 mV	± 45 mV	± 45 mV
10 V	1 kHz	10 V	± 7 mV	± 9 mV	± 10 mV
1 V	1 kHz	10 V	± 3.4 mV	± 4.5 mV	± 4.6 mV
100 mV	1 kHz	10 V	± 13 mV	± 14 mV	± 14 mV

Internal DMM Adjustments

You will need a test input fixture to adjust the internal DMM (see [page 52](#)).

Zero Adjustment

Each time you perform a zero adjustment, the Internal DMM stores a new set of offset correction constants for every measurement function and range. The Internal DMM will sequence through all required functions and ranges automatically and store new zero offset calibration constants. All offset corrections are determined automatically. *You may not correct a single range or function without re-entering ALL zero offset correction constants automatically. This feature is intended to save calibration time and improve zero calibration consistency.*

NOTE

Never turn off the Internal DMM during Zero Adjustment. This may cause ALL calibration memory to be lost.

Zero Adjustment Procedure

The zero adjustment procedure takes about 5 minutes to complete. Be sure to allow the instrument to warm up for 2 hours before performing the adjustments.

Follow the steps outlined below. Review [“DMM Test Considerations”](#) on [page 53](#) before beginning this test.

- 1 This procedure will use the copper shorts installed on input test connector. Leave the Current input connection open.
- 2 Set the DC VOLTS function.
- 3 Send the value 0.000000 to the instrument using the `CALibration:VALue 0.000000` command.
- 4 Calibrate the instrument using the `CALibration?` command.
- 5 Perform the [“Zero Offset Verification”](#) on [page 53](#) to check zero calibration results.

Gain Adjustment

The Internal DMM stores a single new gain correction constant each time this procedure is followed. The gain constant is computed from the calibration value entered for the calibration command and from measurements made automatically during the adjustment procedure.

Most measuring functions and ranges have gain adjustment procedures. Only the 100 M Ω range does not have gain calibration procedures.

Adjustments for each function should be performed **ONLY** in the order shown in the performance verification table. See "[Performance Verification Tests](#)" on page 50 for the tables used for gain adjustments.

Gain Adjustment Considerations

- The zero adjustment procedure must have been recently performed prior to beginning any gain adjustment procedures.
- The optional -10 Vdc adjustment should be performed only after servicing the Internal DMM's a-to-d converter.
- When performing a 4-wire ohms gain adjustment, a new gain correction constant is also stored for the corresponding 2-wire ohms measurement range. If desired, the 2-wire gain can be adjusted separately after the 4-wire ohms gain calibration is completed. If the 2-wire Ohms gain is adjusted separately, the 2-wire Ohms function will not meet specifications when offset compensated Ohms is used.
- During the ac voltage gain adjustments, some of the dc voltage gain constants are used. Perform the dc voltage gain calibration before the ac voltage gain calibration.

NOTE

Never turn off the instrument during a Gain Adjustment. This may cause calibration memory for the present function to be lost.

Valid Gain Adjustment Input Values

Gain adjustment can be accomplished using the following input values.

Function	Range	Valid Calibration Input Values
DC VOLTS	100 mV to 100 V	0.9 to 1.1 x Full Scale
	300 V	250 V to 303 V
OHMS, OHMS 4W	100Ω to 10 MΩ	0.9 to 1.1 x Full Scale
DC CURRENT	10 mA to 1 A	0.9 to 1.1 x Full Scale
AC VOLTS [1]	10 mV to 100 V	0.9 to 1.1 x Full Scale
	300 V	95 V to 303 V
AC CURRENT	1 A	9 mA to 11 mA
FREQUENCY	Any	Any Input > 100 mV rms, 1 kHz –100 kHz

[1] Valid frequencies are as follows: 1 kHz ± 10% for the 1 kHz calibration, 45 kHz–100 kHz for the 50 kHz calibration, and 10 Hz ± 10% for the 10 Hz calibration.

Gain Adjustment Procedure

Adjustment for each function should be performed only in the order shown in the performance verification table. The performance verification tables used for gain adjustments start on [page 55](#).

Review the “[DMM Test Considerations](#)” on page 53 and “[Gain Adjustment Considerations](#)” on page 61 sections before beginning this test.

Configuration: DC functions – 6½ digits
AC functions – LF 3 HZ:SLOW

- 1 Configure each function and range shown in the gain verification tables (starting on [page 55](#)).
- 2 Apply the input signal shown in the “Input” column of the appropriate verification table.

NOTE

Always complete tests in the same order as shown in the appropriate verification table.

- 3 Send the actual input value to the instrument using the `CALibration:VALue <value>` command.
- 4 Calibrate the instrument using the `CALibration?` command.
- 5 Perform the appropriate Gain Verification Test to check the calibration results.
- 6 Repeat steps 1 through 5 for each gain verification test point shown in the tables.

NOTE

Each range in the gain adjustment procedure takes less than 20 seconds to complete.

–10 Vdc Adjustment Procedure (Optional)

The –10 Vdc calibration electronically enhances the Internal DMM's a-to-d converter linearity characteristic. This adjustment should ONLY be performed after servicing the A-to-D converter or replacement of the calibration RAM.

You will need an input test connector as described in "Input Connections" on page 52.

- 1 If a zero calibration has not been performed recently, perform one before beginning this procedure (see [page 60](#)).
- 2 Configure the instrument as follows:

```
DC VOLTS
10 V range      [SENSe:]VOLTage[:DC]:RANGe 10
6½ digits
INTEG 100 PLC  [SENSe:]VOLTage[:DC]:NPLC 100
INPUT R > 10 G [SENSe:]VOLTage[:DC]:IMP:AUTO ON
```
- 3 Measure and note the voltage offset present at the end of the measurement cable by shorting the ends of the cable. Be sure to use a copper wire and allow enough time for the residual thermal offset to stabilize (usually about 1 minute).
- 4 Connect the input cable to the calibrator output and set the calibrator to output +10V. Allow enough settling time for any thermal offset voltages to stabilize (usually about 1 minute).
- 5 Perform a +10V dc gain calibration.
- 6 Send an adjustment to the instrument. The adjustment value is the sum of the calibrator output and the measured offset (from step 3). For example, if the calibrator output is 10.001 volts and the measured offset is 10 μ V, send the value +10.001010 volts. When the adjustment finishes, verify that new readings fall within ± 20 μ V of the calibrator output plus the offset.
- 7 Reverse the cable connections to the calibrator to create a –10 Vdc voltage standard. You must physically reverse the cables. *DO NOT switch the output polarity of the calibrator.*
- 8 Perform a –10V DC gain calibration. Be sure to allow time for thermal offsets to stabilize (usually about 1 minute).
- 9 Send an adjustment to the instrument. The adjustment value is the sum of the calibrator output and the measured offset (from step 3). Using the previous example values, enter 10 μ V minus 10.001 volts or –10.000990 volts.
- 10 When the adjustment finishes, verify that new readings fall within ± 30 μ V of the calibrator output minus the offset.

Plug-in Modules

Plug-in Module Test Considerations

For optimum performance, all test procedures should comply with the following recommendations:

- Assure that the calibration ambient temperature is stable and between 18 °C and 28 °C. Ideally the calibration should be performed at 23 °C ± 1 °C.
- Assure ambient relative humidity is less than 80%.
- Install the plug-in module and allow a 1 hour warm-up period before verification or adjustment.
- Use shielded twisted pair Teflon® insulated cables to reduce settling and noise errors. Keep the input cables as short as possible.
- Remove all user wiring and connections from the plug-in modules before verification or adjustment.
- Use 4-wire Ohms measurement techniques for checking relay contact resistance. Check directly at the terminals where possible.

34951A 4-Ch Isolated DAC Module

Each isolated DAC output channel can be measured and adjusted using the internal DMM. The Internal DMM is recommended because it compensates for ambient temperature.

The 34951A features “auto-calibration”. Upon receipt of the calibration command, all channels on the DAC are adjusted using the internal DMM. Additionally you may adjust **ALL** 34951A modules installed in the instrument with one command. The adjustments require approximately one minute per module.

NOTE

The 34951A 4-Ch Isolated DAC is intended to be adjusted frequently to compensate for changes in the module’s environment (changes in ambient temperature, changing the mainframe slot used, adding or removing modules to a system). These adjustments can be made either volatile or non-volatile as described below. The adjustment procedure is given beginning on [page 70](#).

There are two ways to adjust the DACs, depending upon the state of calibration security (see “[Calibration Security](#)” on page 47).

- If the instrument is secured for calibration when the adjustment is begun, the adjustments are considered volatile. All adjustments are discarded when power is cycled. This provides an easy means to make immediate temperature-compensated adjustments to the DAC outputs without overwriting stored calibration constants.

When this type of adjustment is made, the calibration count (see [page 48](#)) is not advanced.

- If the instrument is unsecured for calibration, the adjustments are written to non-volatile calibration memory. The calibration count (see [page 48](#)) is advanced.

34951A Verification

Test Connections The DAC outputs can be measured using an external voltmeter, or using a test fixture such as the one shown below, with the internal DMM via the ABus connector on the instrument's rear panel.

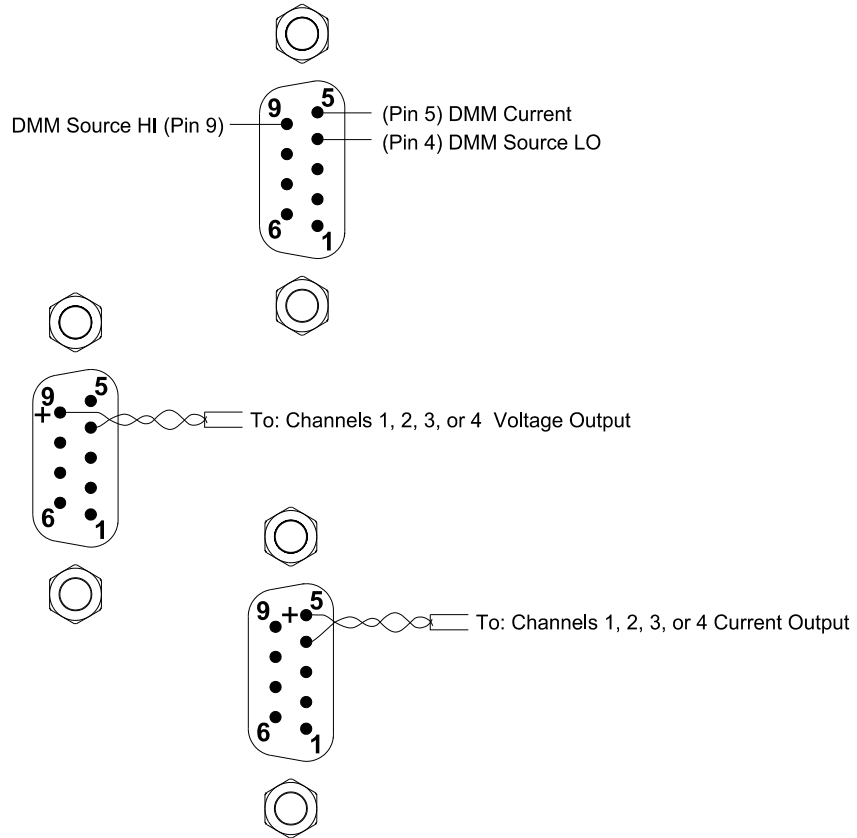

Analog Output Verification Test This procedure is used to check the calibration of the analog outputs on the 34951A 4-channel DAC Module. Verification checks are performed only for those output values with unique calibration constants.

- 1 Using the input test connector described on [page 67](#), leave the current input terminal open. Set the DMM to the 100 mA range. Make and record a current measurement. This value will be used as an offset value during the output current zero verification.
- 2 Make voltage measurement connections to channel 1 of the module.
- 3 Set each output voltage value in the table below and make a measurement. Compare measurement results to the appropriate test limits shown in the table.

NOTE

It is not necessary to test the voltage output at the full rated 10 mA load. If you test the output using a load, connect the sense terminals.

- 4 Make current measurement connections to channel 1 of the module. Set the DMM to the 100 mA range.
- 5 Set each output current value in the table below and make a measurement. Compare measurement results to the appropriate test limits shown in the table. When measuring the 0 mA output value, apply the offset value from step 1 to the measured value.
- 6 Repeat steps 2 through 5 for channels 2, 3 and 4.
- 7 Remove the input test connector.

Output Voltage	Quick Check	Error from Nominal (90 day)
16 V	Q	± 11 mV
12 V		± 9 mV
10 V		± 8 mV
8 V		± 7 mV
4 V		± 5 mV
0 V	Q	± 3 mV
-4V		± 5 mV
-8 V		± 7 mV
-10 V		± 8 mV
-12 V		± 9 mV
-16 V	Q	± 11 mV
Output Current	Quick Check	Error from Nominal (90 day)
20 mA	Q	± 23 µA
15 mA		± 18.5 µA
10 mA		± 14 µA
5 mA		± 9.5 µA
0 mA ^[1]	Q	± 5 µA
-5 mA		± 9.5 µA
-10 mA		± 14 µA
-15 mA		± 18.5 µA
-20 mA	Q	± 23 µA

[1] Apply a measured “0” offset to this measurement.

Analog Output Adjustment

Install the 34951A module in the mainframe and allow a 1 hour warm-up before performing these procedures.

This adjustment procedure sets a zero adjustment and a gain adjustment constant for each DAC output. You must perform all the adjustments on one analog output channel before adjusting the other analog output channel.

- 1 Install the module(s) in the instrument. Remove any inputs from the ABus connector.

CAUTION

Remove any ABus connector before performing this procedure.

- 2 Set the calibration security for the adjustment mode you desire, see [page 66](#).
- 3 Send the `CALibration:MODule? <slot>` command to begin the auto-calibration procedure for all channels on the module in `<slot>`. You may use the `CALibration:MODule? ALL` command to perform the auto-calibration on all channels for all modules installed in the mainframe. The complete procedure may take up to 1 minute per module. Be sure to set the remote command time-out value appropriately.
- 4 The command returns a value of “+0” if the calibration is successful. A returned value of “+1” indicates a calibration failure.

NOTE

Following the auto-calibration procedure, the DMM is left in its reset state (DCV).

34952A Multifunction Module

The only calibration constants are for the two DAC outputs on the 34952A Multifunction Module. These outputs can be measured using an external voltmeter, or with a test fixture such as the one shown below, using the internal DMM via the ABus connector on the instrument's rear panel.

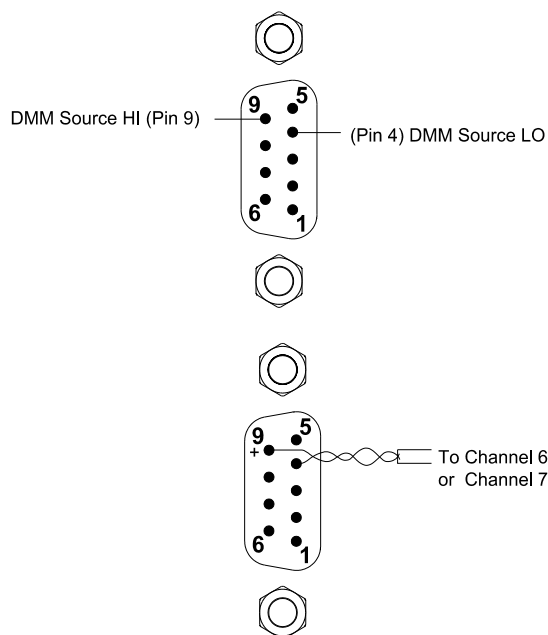

34952A Verification

Analog Output Verification Test This procedure is used to check the calibration of the analog outputs on the 34952A Multifunction Module. Verification checks are performed only for those output values with unique calibration constants.

- 1 Use the internal DMM to measure the output of each channel. You will need to physically move the input connections on the 34952A module to channel 6 and then channel 7.
- 2 For each analog output (channel 6 and channel 7), set each output value in the table on the next page. Compare measurement results to the appropriate test limits shown in the table.

NOTE

It is not necessary to test the voltage output at the full rated 10 mA load.

Output Voltage	Quick Check	Error from Nominal (1 year)
10 V	Q	± 45 mV
0 V	Q	± 20 mV
-10 V		± 45 mV

Analog Output Adjustment

Install the 34952A module in the mainframe and allow a 1 hour warm-up before performing these procedures.

This adjustment procedure sets a zero adjustment and a gain adjustment constant for each DAC output. You must perform all the adjustments on one analog output channel before adjusting the other analog output channel.

- 1 Install the module(s) in the instrument.
- 2 Unsecure the instrument for calibration (see [page 47](#)).
- 3 Connect channel 6 DAC output to the DMM input. Set the DMM to measure DC volts.
- 4 The calibration procedure makes two adjustments per channel. After sending the first command, measure the module output. Send the measured value to the module and advance to the next point. This procedure is summarized as follows:
 - a Send the following command to begin the procedure.
CALibration:BEgin:VOLtage 1, (@<channel>)
 - b Measure the module output.
 - c Send the measured value to the module with the following command:
CALibration:POINT? <value>
 - d The command returns a “+1” to indicate it is ready for the next point.
 - e Measure the module output.
 - f Send the measured value to the module with the following command:
CALibration:POINT? <value>
 - g The command returns a “+0” to indicate the calibration on the channel is completed.
- 5 Repeat steps 3 and 4 for channel 7.

Relay Plug-in Modules

There are two methods you can use to verify relays:

- Read the relay cycle count.
- Measure the relay contact resistance.

Relay Cycle Count

The instrument has a Relay Maintenance System to help you predict relay end-of-life. The instrument counts the cycles on each relay in the instrument and stores the total count in non-volatile memory on each switch module. You can use this feature on any of the relay modules and the internal DMM.

- In addition to the channel relays, you can also query the count on backplane relays and bank relays. Note that you cannot control the state of these relays from the front panel but you can query the count.
- You can also query the state of the six relays on the internal DMM. These relays open or close when a function or range is changed on a module.
- You can reset the count but the instrument must be unsecured (see [“Calibration Security”](#) on page 47 to unsecure the instrument).
- The 34923A, 34924A, and 34933A modules can be configured for 2-wire (differential) or 1-wire (single ended) measurements. Since two coils are required to drive each channel relay in the 2-wire mode, the module stores the cycle count for each coil and returns the greater of the two. To determine the cycle count for each coil, reconfigure the module for the 1-wire mode (a power cycle is required) and query the count.
- The FET switches on the 34925A FET Multiplexer module have an infinite life when used under normal operating conditions. Therefore, the cycle count is not recorded and this command always returns “0” (will not generate an error). Although the count on the FET switches is not recorded, you can read the actual cycle count on the mechanical Analog Bus relays.
- On the RF Multiplexer modules (34941A, 34942A), the signal path to the COM terminal consists of both a channel relay and a bank relay. For each bank, the module stores the cycle count for each channel relay, the bank relay, and returns the greater of the two. For example, to determine the cycle count on Channel 11, the module recalls the count on Channel 11, the count on the Bank 1 relay, and returns the greater of the two. In addition, the cycle count on the two channels within the same physical relay package, will always be equal. Therefore, the cycle count for Channels 11 and 12 will always be equal.

Use the `DIAGnostic:RELAy:CYCLes? (@<ch_list>)` command to read relay cycle counts on the following modules:

- 34921A through 34925A Multiplexer Modules
- 34931A through 34933A Matrix Modules
- 34937A and 34938A GP Switch Modules
- 34941A and 34942A RF Multiplexer Modules
- 34946A and 34947A Microwave Switch Modules

Use the `DIAGnostic:DMM:CYCLes? {1|2|3|4|5|6}` command to read relay cycle counts for the internal DMM function and range relays.

By maintaining a count you can estimate which relays are nearing the end of their useful life.

Relay Contact Resistance Verification (Optional)

The Agilent Y1131A Verification/Diagnostic Software Kit contains software and hardware used to test the relay switching modules available for the Agilent 34980A Multifunction Switch/Measure Unit. The software provides module-specific tests to assist you with troubleshooting possible relay failures and predicting system maintenance requirements. Custom terminal blocks are provided to route signals and isolate individual relays for verification and diagnostics.

For several of the relay switching modules, it is very difficult to isolate a particular channel. The Y1131A Verification/Diagnostic Software used in conjunction with the provided verification terminal blocks attempts to isolate measurement channels in a repeatable manner.

Thermocouple Reference Junction 34921A (Optional)

NOTE

You should perform these verification if you are using the module for thermocouple measurements.

To make a thermocouple measurement a known reference junction temperature measurement must be made. The reference junction temperature is measured by two solid state temperature sensors in the input connection area on the module. The adjustments store calibration constants used to correct the measurements from the temperature sensors.

Thermocouple measurements using an internal reference are only supported by the 34921A module using the optional 34921T terminal block. The isothermal block is located on, and is an integral part of, the terminal block.

There are no adjustments for the reference junction.

Thermocouple Reference Junction Verification

- 1 Read "Plug-in Module Test Considerations" on page 65.
- 2 Connect a calibrated thermocouple to channel 21.
- 3 Install the module in slot 1.
- 4 Place the J Type calibrated thermocouple at a known temperature (ice bath or calibrator).
- 5 Select Channel 21. Configure the channel as follows:

```
TEMPERATURE
THERMOCOUPLE
J TYPE
INTEG 10 PLC
INTERNAL REF
```

```
SENS:TEMP:TRAN:TYPE TC, (@1021)
SENS:TEMP:TRAN:TC:TYPE J, (@1021)
SENS:TEMP:NPLC 10, (@1021)
SENS:TEMP:TRANS:TC:RJUN:TYPE INT, (@1021)
```
- 6 Subtract the thermocouple error from the measured temperature. Verify the result is within ± 1.0 °C of the known temperature (set in step 4).

3 Calibration Procedures



4 Troubleshooting and Diagnostics

Troubleshooting Hints	78
Power Supply	79
Product Firmware Updates	79
Instrument Errors	80
Error Numbers	82
Isolate a Problem with a Plug-In Module	90
Relay and FET Replacement	91
34921A 40-Channel Armature Multiplexer with Low Thermal Offset	92
34922A 70-Channel Armature Multiplexer	94
34923A 40/80-Channel Reed Multiplexer	96
34924A 70-Channel Reed Multiplexer	98
34925A 40/80-Channel Optically-Isolated FET Multiplexer	100
34931A Dual 4x8 Armature Matrix	102
34932A Dual 4x16 Armature Matrix	104
34933A Dual/Quad 4x8 Reed Matrix	107
34937A 32-Channel GP Switch	111
34938A 20-Channel High-Current GP Switch	112



Troubleshooting and Diagnostics

This chapter provides basic instructions to isolate a problem.

Troubleshooting Hints

This section provides a brief checklist of common failures. Before troubleshooting the instrument, be sure the failure is in the instrument rather than any external connections.

Unit seems inoperative

- 1 Verify the ac power cord is connected to the instrument.
- 2 Press the front panel power switch.
- 3 Listen for the fan (on the right side of the instrument) to isolate a problem with the front panel.
- 4 Remove all plug-in modules to verify a module is not causing the failure.
- 5 Verify the power supply as described on [page 79](#).

Isolating to an assembly

- 1 Remove all plug-in modules from the mainframe.
- 2 Remove any connections to the Analog Bus.
- 3 Turn on power and listen for the beep and fan operation. The fan operates from the main power supply.
- 4 Isolate the internal DMM by removing it from the instrument. The instrument should turn on and pass self-test without the internal DMM installed. Disassembly procedures begin on [page 115](#).

Unit fails self-test

- 1 Check the display for the power on self test results.
- 2 Remove all plug-in modules from the mainframe and any connections to the Analog Bus. Run the self-test again. A passing self-test indicates a problem with a plug-in module. Replace the plug-in modules one at a time to isolate the failing module.
- 3 If the self test still fails, remove the internal DMM from the instrument. The instrument should turn on and pass self-test without the internal DMM installed. Disassembly procedures begin on [page 115](#).
- 4 Self-test errors are described beginning on [page 82](#).

Power Supply

The main power supply provides +12 Volts. All other power supplies are derived from this supply. To test the main power supply:

WARNING

Exposed Mains. When the instrument cover is removed to test the power supply, the ac mains are exposed.

- 1 Disassemble the instrument as described beginning on [page 115](#).
- 2 Use a DVM to check that the power supply output is $+12\text{ V} \pm 0.6\text{ V}$. Test the power supply output at the red leads on the power supply connector to the communications board.
 - a The +12 Volt supply is always on when the ac power is applied to the instrument. Test for loading errors by unplugging the power supply connector from the communications board.
- 3 Use an oscilloscope to verify there is no ac oscillation on the +12 V power supply.

Replace the power supply assembly if +12 V is not present.

Product Firmware Updates

As new product features and enhancements become available, you can easily update your mainframe and plug-in module firmware to ensure optimum compatibility. The latest firmware updates are available from the Agilent 34980A product page at www.agilent.com/find/34980AUpdates.

Front Panel Operation: Utility > FIRMWARE > UPDATE

Once you have downloaded the latest mainframe firmware (see above), use the knob to scroll through the installed modules that require a firmware update. To exit the menu without installing the updates, select CANCEL.

Instrument Errors

A record of up to 20 errors can be stored in the instrument's error queue. Each remote interface I/O session (i.e., GPIB, USB, LAN, etc.) has its own interface-specific error queue. Errors appear in the error queue of the I/O session that caused the error. For example, if an error was generated by a command sent over the GPIB interface, send this command from GPIB to read the error queue.

The instrument beeps once each time a command syntax or hardware error is generated. The front-panel ERROR annunciator turns on when one or more errors are currently stored in the error queue.

A special global error queue holds all power-on and hardware-related errors (e.g., over-temperature, Safety Interlock, etc.).

Errors are retrieved in first-in-first-out (FIFO) order. The first error returned is the first error that was stored. Once you have read all of the interface-specific errors, the errors in the global error queue are retrieved.

Errors are cleared as you read them. When you have read all errors from the interface-specific and global error queues, the ERROR annunciator turns off and the errors are cleared.

If more than 20 errors have occurred, the last error stored in the queue (the most recent error) is replaced with -350,"Error queue overflow". No additional errors are stored until you remove errors from the queue. If no errors have occurred when you read the error queue, the instrument responds with +0,"No error".

The front panel reports errors from all I/O sessions as well as the global error queue. To read the error queue from the front panel, use the View key.

Error conditions are also summarized in the Status Byte Register. For more information on the SCPI Status System for the Agilent 34980A, see Status System Introduction.

The interface-specific and global error queues are cleared by the *CLS (Clear Status) command and when power is cycled. The errors are also cleared when you read the error queue. The error queue is not cleared by a Factory Reset (*RST command) or an Instrument Preset (SYSTEM:PRESet command).

Front-Panel Operation

If the ERROR annunciator is on, press [View] to view the errors. Use the knob to scroll through the error numbers. Press [>] to view the text of the error message. Press [>] again to increase the scrolling speed (the final key press cancels the scroll). All errors are cleared when you exit the menu.

Remote Interface Operation

SYSTem:ERRor? Read and clear one error from the queue

Errors have the following format (the error string may contain up to 80 characters):

-113,"Undefined header"

Error Numbers

The following sections list the error numbers and error descriptions that may be reported by the instrument. Not all these errors indicate a hardware failure.

Execution Errors

These errors typically do not indicate a hardware failure. They are related to illegal or improper operation of the instrument using the remote interface.

Error	Description
r	
-101	"Invalid character"
-102	"Syntax error"
-103	"Invalid separator"
-113	"Undefined header"
-123	"Numeric overflow"
-213	"INIT ignored"
-222	"Data out of range; value set to upper limit"
-222	"Data out of range; value set to lower limit"
-224	"Illegal parameter value ranges must be positive"
-230	"Data stale"
-231	"Internal software error"
-313	"Calibration memory lost; memory corruption detected"
-313	"Calibration memory lost; due to firmware revision change"
-314	"Save/recall memory lost; memory corruption detected"
-314	"Save/recall memory lost; due to firmware revision change"
-315	"Configuration memory lost; memory corruption detected"
-315	"Configuration memory lost; due to firmware revision change"
-321	"Out of memory; use definite length block for large traces"
-350	"Error queue overflow"
-350	"DMM processor error queue overflowed"
-410	"Query INTERRUPTED"
-420	"Query UNTERMINATED"

Instrument Errors

These errors typically do not indicate a hardware failure. They are related to improper settings usually in command parameters.

Error	Description
111	"Channel list: slot number out of range"
112	"Channel list: channel number out of range"
113	"Channel list: empty scan list"
114	"Channel list: ABus channels not allowed as endpoint in range"
201	"Memory lost: stored state"
202	"Memory lost: power-on state"
203	"Memory lost: stored readings"
204	"Memory lost: time and date"
221	"Settings conflict: calculate limit state forced off"
222	"Settings conflict: module type does not match state"
222	"Settings conflict: Scan list cleared"
223	"Settings conflict: trig source changed to IMM"
224	"Settings conflict: chan adv source changed to IMM"
225	"Settings conflict: DMM disabled or missing"
226	"Settings conflict: DMM enabled"
227	"Settings conflict: DMM not installed"
251	"Unsupported temperature transducer type"
261	"Not able to execute while scan initiated"
262	"Not able to abort scan"
263	"Not able to execute while DMM is measuring"
264	"Not a scannable channel"
271	"Not able to accept unit names longer than 3 characters"
272	"Not able to accept character in unit name"
281	"Not able to perform on more than one channel"
291	"Not able to recall state: it is empty"
292	"Not able to recall state: DMM enable changed"

Error	Description
301	"Module currently committed to scan"
302	"No module was detected in this slot"
303	"Module is not able to perform requested operation"
304	"Does not exist"
305	"Not able to perform requested operation"
306	"Part of a 4-wire pair"
307	"Incorrectly configured ref channel"
308	"Channel not able to perform requested operation"
309	"Incorrectly formatted channel list"
310	"Operation refused because channel is locked open"
311	"Not able to specify resolution with Auto range"
501	"Isolator UART framing error"
502	"Isolator UART overrun error"
514	"Not allowed"
514	"Not allowed; Instrument locked by another I/O session"
521	"Communications: input buffer overflow"
521	"Input buffer overflow"
522	"Output buffer overflow"
522	"Communications: output buffer overflow"
531	"Insufficient memory"
532	"Cannot achieve requested resolution"
532	"Not able to achieve requested resolution"
540	"Cannot use overload as math reference"
540	"Not able to null channel in overload"
550	"Command not allowed in local"
550	"Not able to execute command in local mode"
551	"Unknown Dmm Inguard Error"

Self-Test Errors

These errors can indicate a hardware failure. The first two errors, 601 and 602, can indicate a failure of the communications board. The remaining errors are typically caused by a failure on the internal DMM.

Error	Description
601	"Self-test: front panel not responding"
602	"Self-test: RAM read/write"
603	"Self-test: A/D sync stuck"
604	"Self-test: A/D slope convergence"
605	"Self-test/Cal: not able to calibrate rundown gain"
606	"Self-test/Cal: rundown gain out of range"
607	"Self-test: rundown too noisy"
608	"Serial configuration readback failed"
609	"DC gain x1 failed"
610	"DC gain x10 failed"
611	"DC gain x100 failed"
612	"Ohms 500 nA source failed"
613	"Ohms 5 uA source failed"
614	"DC 1000V zero failed"
615	"Ohms 10 uA source failed"
616	"DC current sense failed"
617	"Ohms 100 uA source failed"
618	"DC high voltage attenuator failed"
619	"Ohms 1 mA source failed"
620	"AC rms zero failed"
621	"AC rms full scale failed"
622	"Frequency counter failed"
623	"Cannot calibrate precharge"
624	"Unable to sense line frequency"
625	"I/O processor does not respond"
626	"I/O processor failed self-test"

Calibration Errors

The following errors indicate failures that may occur during a calibration. Often, performing the calibration again will clear these errors.

Error	Description
701	"Cal security disabled by jumper"
702	"Cal: secured"
703	"Cal: invalid secure code"
704	"Cal: secure code too long"
705	"Cal: aborted"
706	"Cal: value out of range"
707	"Cal: signal measurement out of range"
708	"Cal: signal frequency out of range"
709	"Cal: no cal for this function or range"
710	"Cal: full scale correction out of range"
711	"Cal: cal string too long"
720	"Cal: DCV offset out of range"
721	"Cal: DCI offset out of range"
722	"Cal: RES offset out of range"
723	"Cal: FRES offset out of range"
724	"Cal: extended resistance self cal failed"
725	"Cal: 300V DC correction out of range"
730	"Cal: precharge DAC convergence failed"
731	"Cal: A/D turnover correction out of range"
732	"Cal: AC flatness DAC convergence failed"
733	"Cal: AC low frequency convergence failed"
734	"Cal: AC low frequency correction out of range"
735	"Cal: AC rms converter noise correction out of range"
736	"Cal: AC rms 100th scale correction out of range"
740	"Cal data lost: secure state"
741	"Cal data lost: string data"
742	"Cal data lost: DCV corrections"
743	"Cal data lost: DCI corrections"
744	"Cal data lost: RES corrections"
745	"Cal data lost: FRES corrections"
746	"Cal data lost: AC corrections"
747	"Calibration failed"
747	"Cal checksum failed, GPIB address"
748	"Cal checksum failed, internal data"
748	"Cal: mainframe cal memory write failure"
748	"Cal: invalid while cal in progress"
748	"Firmware and FPGA revision mismatch"
748	"Cal: no cal in progress"
749	"DMM relay count data lost"

Firmware Update Errors

These errors occur when attempting to update the mainframe, internal DMM, or plug-in modules.

Error	Description
791	"Firmware update error; unable to begin download"
792	"Firmware update error; programming operation failed"
793	"Firmware update error; data record invalid character"
794	"Firmware update error; data record length mismatch"
795	"Firmware update error; data record checksum mismatch"
796	"Firmware update error; bad checksum for download start"
797	"Firmware update error; bad checksum for download complete"
798	"Firmware update error; download in progress"
799	"Firmware update error; unable to complete download"
800	"Firmware update error; invalid programming address"
810	"State has not been restored"
811	"Operation has not been implemented"

Plug-In Module Errors

These errors are related to the plug-in modules and often indicate a failing module.

Error	Description
901	"Module hardware: unexpected data received"
902	"Module hardware: missing stop bit"
903	"Module hardware: data overrun"
904	"Module hardware: protocol violation"
905	"Module hardware: early end of data"
906	"Module hardware: missing end of data"
907	"Module hardware: module SRQ signal stuck low"
908	"Module hardware: not responding"
910	"Module reported an unknown module type"
911	"Module reported command buffer overflow"
912	"Module reported command syntax error"
913	"Module reported nonvolatile memory fault"
914	"Module reported temperature sensor fault"
915	"Module reported firmware defect"
916	"Firmware update required (www.agilent.com/find/34980AUpdates)"
917	"Module reported overvoltage"
918	"Module reported that maximum number of switches are closed"
919	"Module reported that switch is missing"
920	"Module reported that FPGA update failed"
921	"Module reported that its boot test failed"
922	"Module reported error byte containing unknown error(s)"
923	"DAC Module reported no trace assigned to channel"
924	"Module reported trace download failed"
925	"Module does not support trace"
926	"Invalid width for digital channel"
927	"Trace does not exist"
928	"Module reported ABus safety interlock activated"
929	"Module reported overtemperature"
930	"Module backplane error"
931	"Backplane module transaction failed"
932	"Safety Interlock prevents completion of this command. Check Terminal connection."
933	"Revision mismatch between module firmware and FPGA"
934	"Backplane interrupt line stuck asserted, service disabled"

Error	Description
935	"Trace of that name already exists"
936	"Cannot delete active trace"
937	"Digital channel not capable of specified width"
940	"State of switch unknown"
941	"No remote module present"
942	"Remote module not powered"
943	"Remote module topology change"
944	"Channel drive is paired"
945	"Remote module commands are unsupported on this slot"
946	"Remote module is unable to perform requested operation"
947	"Channel is not accessible"
948	"Invalid/missing remote module specifier"
949	"Open operation not valid for this channel configuration"
950	"Illegal operation when channel drive enabled"
951	"Switch failed to verify as expected"
952	"Internal channel drive illegal for remote slave module"
953	"Overcurrent detected"
954	"Remote modules configured in an illegal topology"
955	"Illegal operation when remote module's channel drive disabled"
956	"Module hardware: unexpected transaction termination"

Isolate a Problem with a Plug-In Module

Any module that fails the mainframe self-test or generates a mainframe error must be replaced at the module level. Only the relay and FET switches have field replaceable parts. The following table summarizes the repair strategy for the plug-in modules.

Model	Description	Repair Strategy
34921A	40-channel armature multiplexer	Relay and Fuse replacement only
34923A	40/80-channel reed multiplexer	Relay replacement only
34925A	40/80-channel optically isolated FET multiplexer	FET replacement only
34922A	70-channel armature multiplexer	Relay and Fuse replacement only
34924A	70-channel reed multiplexer	Relay replacement only
34931A	Dual 4x8 armature matrix	Relay replacement only
34932A	Dual 4x16 armature matrix	Relay replacement only
34933A	Dual/quad 4x8 reed matrix	Relay replacement only
34937A	32-channel Form C/Form A general-purpose switch	Relay replacement only
34938A	20-channel 5-amp Form A switch	Relay replacement only
34941A	Quad 1x4 50-ohm 3-GHz RF multiplexer	Module replacement
34942A	Quad 1x4 75-ohm 1.5 GHz RF multiplexer	Module replacement
34945A	Microwave switch/attenuator driver	Module replacement
34946A	Dual 1x2 SPDT terminated microwave switch	Module replacement
34947A	Triple 1x2 SPDT unterminated microwave switch	Module replacement
34950A	64-bit digital I/O with memory and counter	Module replacement
34951A	4-channel isolated D/A converter	Module replacement
34952A	Multifunction module	Module replacement
34959A	Breadboard module	Module replacement

Relay and FET Replacement

Failing relays and FET switches can be isolate to a specific channel and replaced. There are two methods you can use to verify relays and switches:

- Read the relay cycle count.
- Measure the relay contact resistance.

The Agilent Y1131A Verification/Diagnostic Software Kit is a recommended tool and contains software and hardware used to test the relay switching modules available for the Agilent 34980A Multifunction Switch/Measure Unit. The software provides module-specific tests to assist you with troubleshooting possible relay failures and predicting system maintenance requirements. Custom terminal blocks are provided to route signals and isolate individual relays for verification and diagnostics.

For several of the relay switching modules, it is very difficult to isolate a particular channel. The Y1131A Verification/Diagnostic Software used in conjunction with the provided verification terminal blocks attempts to isolate measurement channels in a repeatable manner.

34921A 40-Channel Armature Multiplexer with Low Thermal Offset

The 34921A 40-Channel Armature Multiplexer (40-Ch Arm MUX) is divided into two banks with 20 latching armature switches (channels 1- 20 and 21- 40) in each. This module also offers four additional fused relays (channels 41- 44) for making AC and DC current measurements with the internal DMM with no external shunts needed. These current channels feature “make-before-break” connections to ensure continuous current flow when switching from one current channel to another. The current fuses are replaceable.

This module also contains nine armature Analog Bus relays (channels 911- 914, 921-924, and 931), four on each bank that can connect the bank relays to the system Analog Buses and one that connects the current relays to the current input of the DMM. Through ABus1 and ABus2 you can connect any of the channels to the internal DMM for voltage or resistance measurements. Refer to the simplified schematic below.

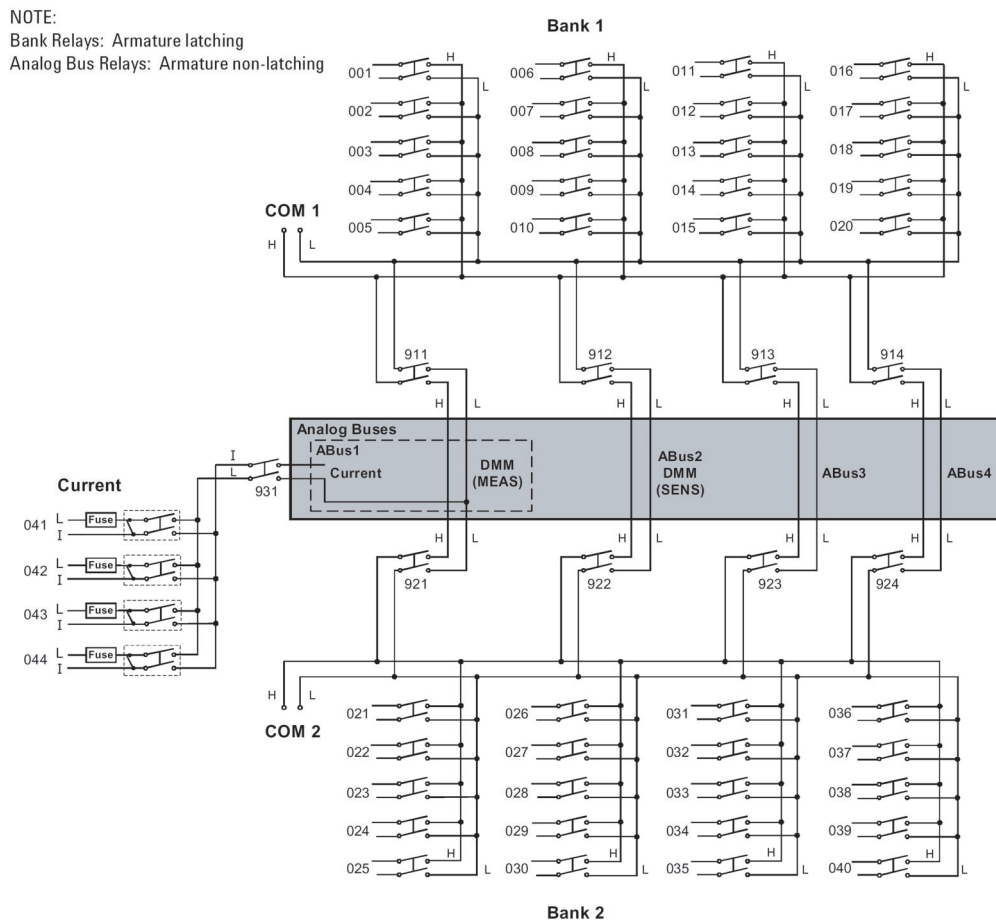

For the 34921A, relay and fuse part numbers are given on [page 126](#) and the component locator is shown on [page 136](#). The table below shows the relationship of channel numbers to relay numbers.

Bank 1		Bank 2	
Channel	Relay	Channel	Relay
001	K601	021	K721
002	K602	022	K722
003	K603	023	K723
004	K604	024	K724
005	K605	025	K725
006	K606	026	K726
007	K607	027	K727
008	K608	028	K728
009	K609	029	K729
010	K610	030	K730
011	K611	031	K731
012	K612	032	K732
013	K613	033	K733
014	K614	034	K734
015	K615	035	K735
016	K616	036	K736
017	K617	037	K737
018	K618	038	K738
019	K619	039	K739
020	K620	040	K740
Backplane		Backplane	
911	K911	921	K921
912	K912	922	K922
913	K913	923	K923
914	K914	924	K924
Current*		Current*	
041	K841, K841S, F1041	043	K843, K843S, F1043
042	K842, K842S, F1042	044	K844, K844S, F1044
Current Backplane			
931	K931		

*The current switches use two relays to create a “make-before-break” circuit. You should replace both relays.

34922A 70-Channel Armature Multiplexer

The high-density 34922A 70-Channel Armature Multiplexer (70-Ch Arm MUX) is divided into two banks with 35 latching armature switches (channels 1-35 and 36-70) in each. This module also contains eight armature Analog Bus relays (channels 911-914 and 921-924), four on each bank that can connect the bank relays to the system Analog Buses. Through ABus1 and ABus2 you can connect any of the channels to the internal DMM for voltage or resistance measurements. Refer to the simplified schematic below.

NOTE:
 Bank Relays: Armature latching
 Analog Bus Relays: Armature non-latching

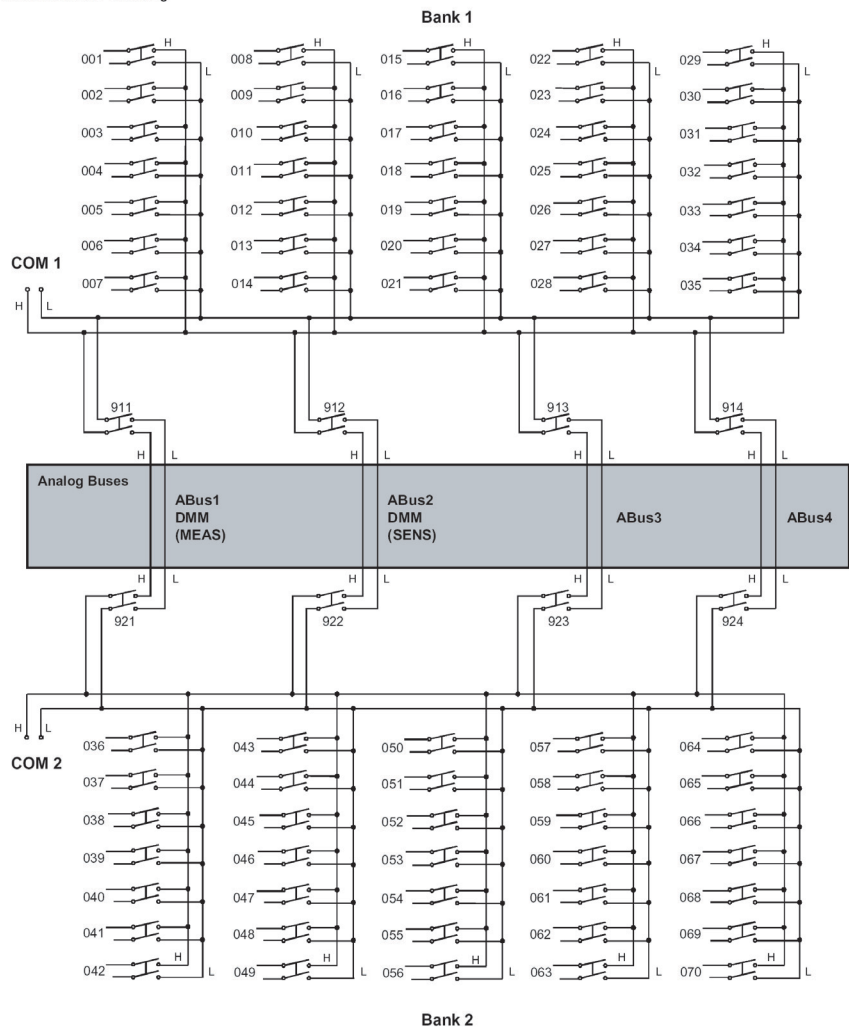

For the 34922A, relay part numbers are given on [page 126](#) and the component locator is shown on [page 137](#). The table on the next page shows the relationship of channel numbers to relay numbers.

Bank 1		Bank 2	
Channel	Relay	Channel	Relay
001	K601	036	K736
002	K602	037	K737
003	K603	038	K738
004	K604	039	K739
005	K605	040	K740
006	K606	041	K741
007	K607	042	K742
008	K608	043	K743
009	K609	044	K744
010	K610	045	K745
011	K611	046	K746
012	K612	047	K747
013	K613	048	K748
014	K614	049	K749
015	K615	050	K750
016	K616	051	K751
017	K617	052	K752
018	K618	053	K753
019	K619	054	K754
020	K620	055	K755
021	K621	056	K756
022	K622	057	K757
023	K623	058	K758
024	K624	059	K759
025	K625	060	K760
026	K626	061	K761
027	K627	062	K762
028	K628	063	K763
028	K629	064	K764
030	K630	065	K765
031	K631	066	K766
032	K632	067	K767
033	K633	068	K768
034	K634	069	K769
035	K635	070	K770
Backplane		Backplane	
911	K811	921	K821
912	K812	922	K822
913	K813	923	K823
914	K814	924	K824

34923A 40/80-Channel Reed Multiplexer

The 34923A 40/80-Channel Reed Multiplexer (40/80-Ch Reed MUX) is divided into two equal banks of non-latching reed switches. This module also contains eight armature Analog Bus relays (channels 911-914 and 921-924), four on each bank that can connect the bank relays to the system Analog Buses. You can connect any of the channels to the internal DMM through ABus1 and ABus2 for voltage or resistance measurements.

Using program commands or the mainframe front panel, you can control each of the channel switches individually, and configure this module for differential (2-wire or 4-wire) or single-ended (1-wire) mode. Refer to the simplified schematic for two- or four-wire modes.

NOTE:

Bank Relays: Reed non-latching
 Analog Bus Relays: Armature non-latching

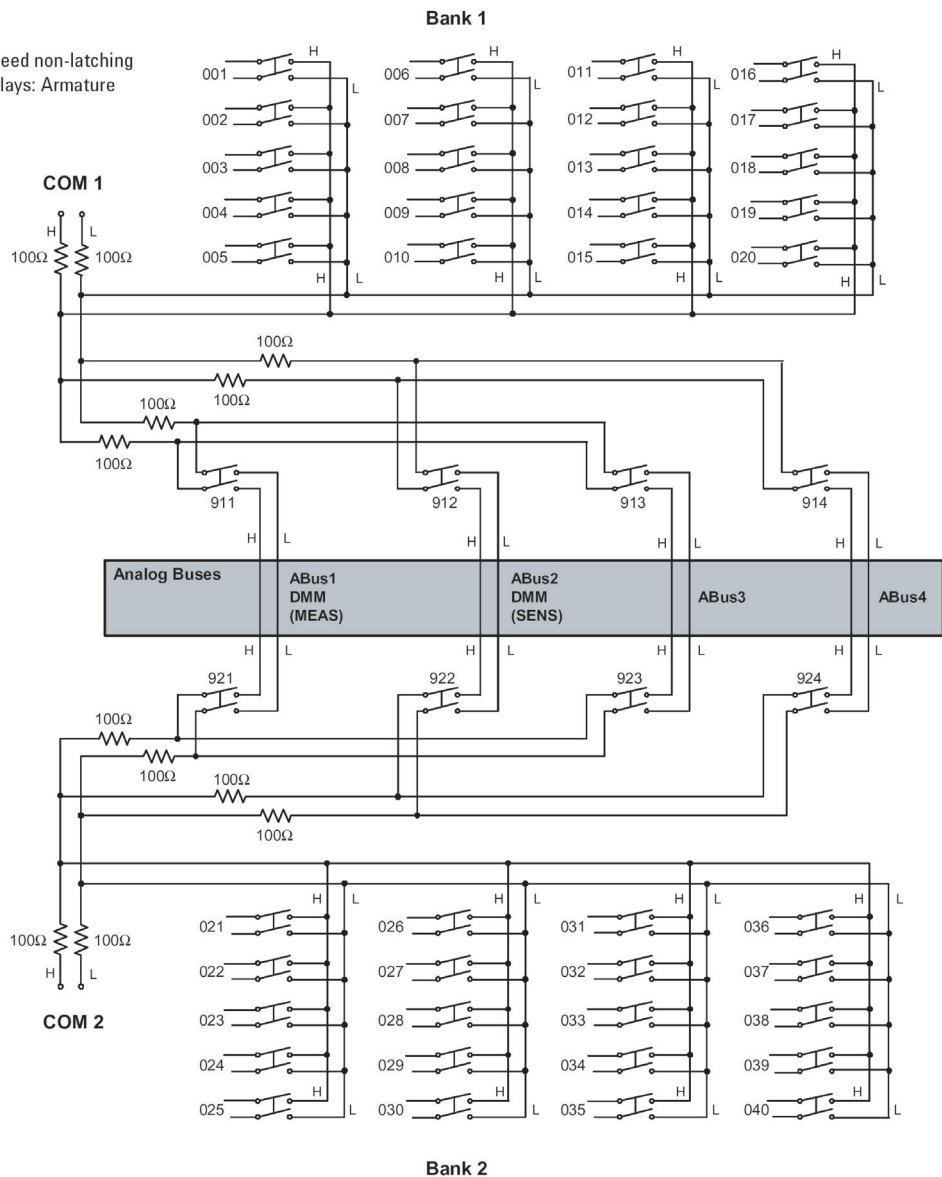

For the 34923A, relay part numbers are given on [page 127](#) and the component locator is shown on [page 138](#). The table below shows the relationship of channel numbers to relay numbers.

Bank 1			Bank 2		
2-, 4-Wire Channel	1-wire Channel	Relay	2-, 4-Wire Channel	1-Wire Channel	Relay
001	001, 002	K401	021	041, 042	K501
002	003, 004	K401	022	043, 044	K501
003	005, 006	K402	023	045, 046	K502
004	007, 008	K403	024	047, 048	K503
005	009, 010	K405	025	049, 050	K505
006	011, 012	K401	026	051, 052	K501
007	013, 014	K402	027	053, 054	K502
008	015, 016	K403	028	055, 056	K503
009	017, 018	K404	029	057, 058	K504
010	019, 020	K404	030	059, 060	K504
011	021, 022	K401	031	061, 062	K501
012	023, 024	K401	032	063, 064	K501
013	025, 026	K403	033	065, 066	K503
014	027, 028	K404	034	067, 068	K504
015	029, 030	K405	035	069, 070	K505
016	031, 032	K402	036	071, 072	K502
017	033, 034	K403	037	073, 074	K503
018	035, 036	K404	038	075, 076	K504
019	037, 038	K405	039	077, 078	K505
020	039, 040	K405	040	079, 080	K505
	Backplane			Backplane	
911		K611	921		K621
912		K612	922		K622
913		K613	923		K623
914		K614	924		K624

34924A 70-Channel Reed Multiplexer

The high-density 34924A 70-Channel Reed Multiplexer (70-Ch Reed MUX) is divided into two banks with 35 non-latching reed switches (channels 1-35 and 36-70) in each. This module also contains eight armature Analog Bus relays (channels 911-914 and 921-924), four on each bank that can connect the bank relays to the system Analog Buses. Through ABus1 and ABus2 you can connect any of the channels to the system DMM for voltage or resistance measurements. See the simplified schematic below.

NOTE:
 Bank relays: Reed non-latching
 Analog Bus relays: Armature non-latching

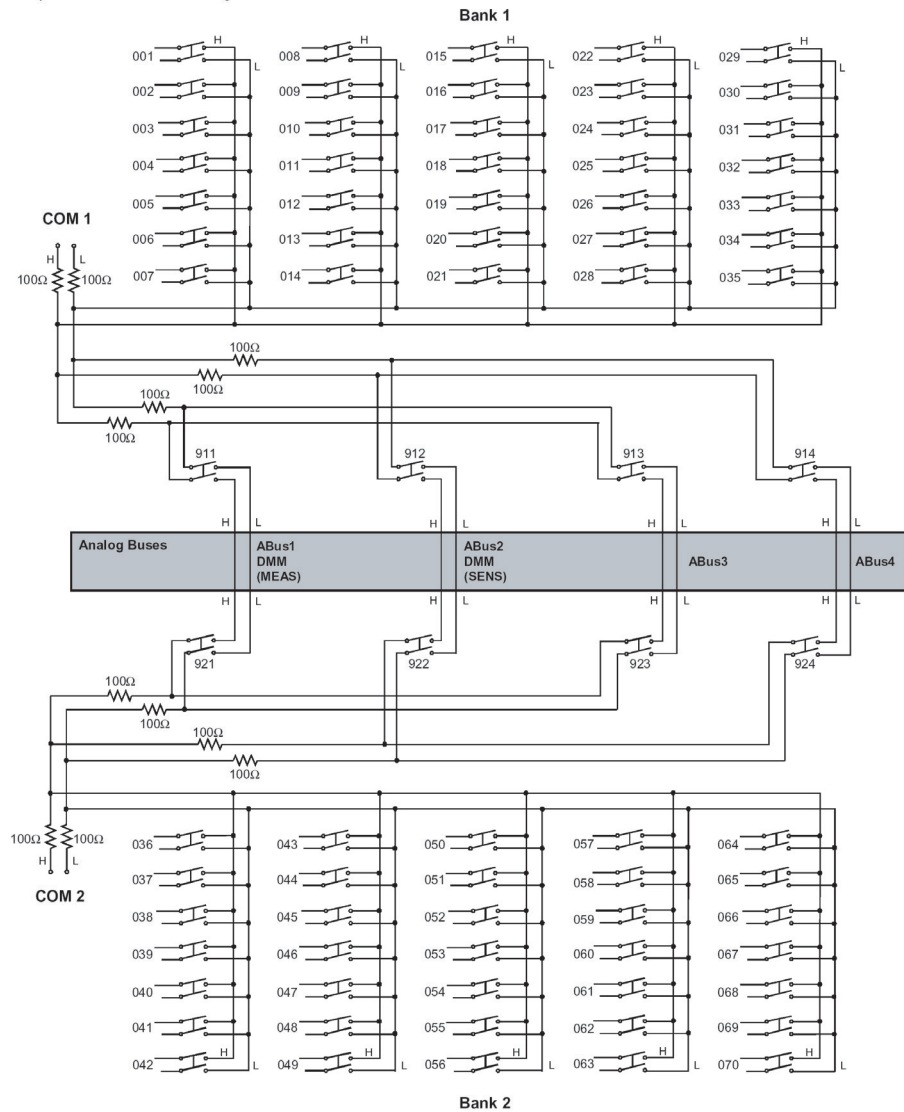

For the 34924A, relay part numbers are given on [page 127](#) and the component locator is shown on [page 139](#). The table below shows the relationship of channel numbers to relay numbers.

Bank 1		Bank 2	
Channel	Relay	Channel	Relay
001	K401	036	K501
002	K403	037	K503
003	K404	038	K504
004	K408	039	K508
005	K408	040	K508
006	K402	041	K502
007	K403	042	K503
008	K404	043	K504
009	K409	044	K509
010	K407	045	K507
011	K401	046	K501
012	K404	047	K505
013	K404	048	K504
014	K408	049	K508
015	K408	050	K508
016	K402	051	K502
017	K403	052	K503
018	K404	053	K505
019	K409	054	K509
020	K407	055	K507
021	K401	056	K501
022	K403	057	K503
023	K404	058	K504
024	K409	059	K509
025	K407	060	K507
026	K402	061	K502
027	K404	062	K505
028	K406	063	K506
028	K407	064	K507
030	K409	065	K509
031	K402	066	K502
032	K401	067	K501
033	K404	068	K505
034	K406	069	K506
035	K406	070	K506
Backplane		Backplane	
911	K611	921	K621
912	K612	922	K622
913	K613	923	K623
914	K614	924	K624

34925A 40/80-Channel Optically-Isolated FET Multiplexer

The 34925A 40/80-Channel Optically-Isolated FET Multiplexer (40/80-Ch FET MUX) module is a high-speed and high-density FET MUX for high throughput production test. This module is divided into two equal banks of non-latching FET switches. This module also contains four armature Analog Bus relays. Through ABus1 and ABus2 you can connect any of the channels to the internal DMM for voltage or resistance measurements. When the power is off, all channel and Analog Bus relays open.

Using program commands or the mainframe front panel, you can control each of the FET channel switches individually, and configure this module for differential (2-wire or 4-wire) or single-ended (1-wire) mode. Refer to the simplified 2-, 4-wire schematic below.

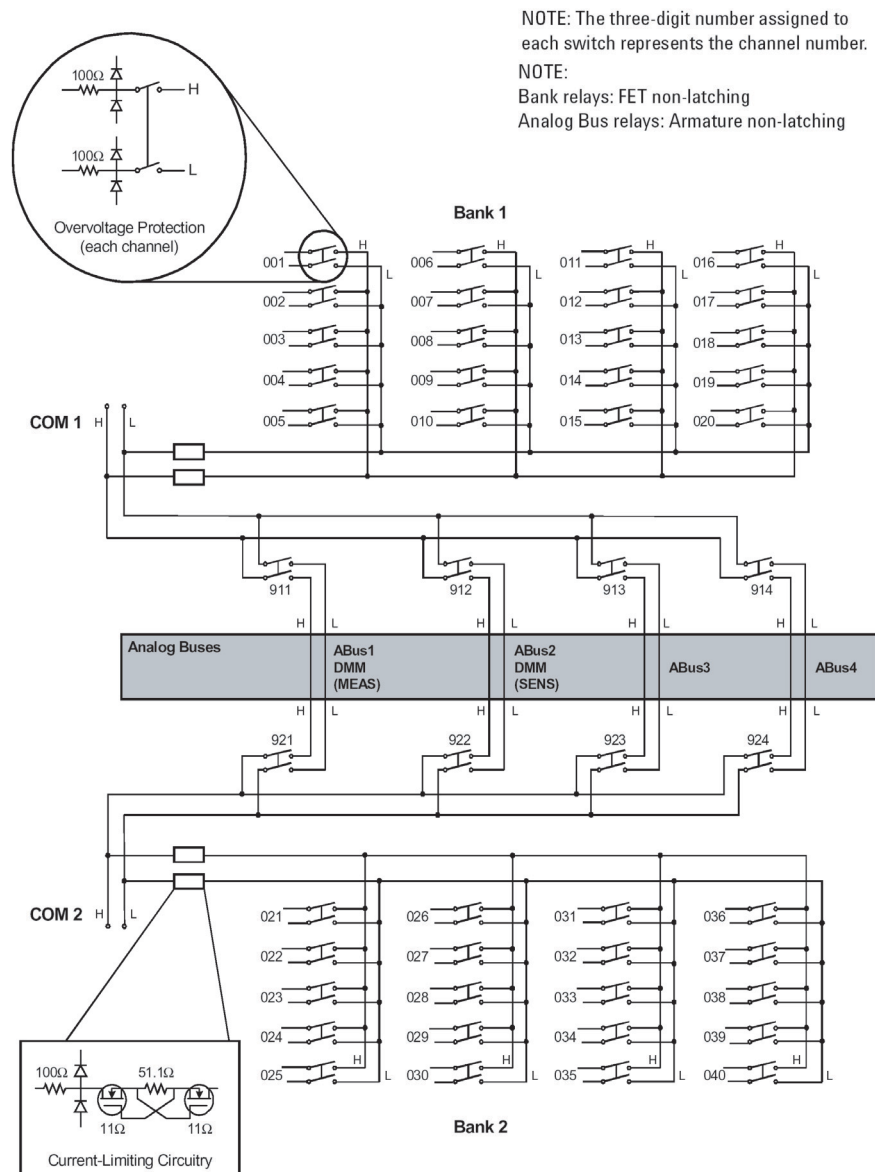

For the 34925A, FET part numbers are given on [page 127](#) and the component locator is shown on [page 140](#). The table below shows the relationship of channel numbers to relay numbers.

Bank 1			Bank 2		
2-, 4-Wire Channel	1-wire Channel	FET	2-, 4-Wire Channel	1-Wire Channel	FET
001	001, 002	U601	021	041, 042	U701
002	003, 004	U602	022	043, 044	U702
003	005, 006	U603	023	045, 046	U703
004	007, 008	U604	024	047, 048	U704
005	009, 010	U605	025	049, 050	U705
006	011, 012	U606	026	051, 052	U706
007	013, 014	U607	027	053, 054	U707
008	015, 016	U608	028	055, 056	U708
009	017, 018	U609	029	057, 058	U709
010	019, 020	U610	030	059, 060	U710
011	021, 022	U611	031	061, 062	U711
012	023, 024	U612	032	063, 064	U712
013	025, 026	U613	033	065, 066	U713
014	027, 028	U614	034	067, 068	U714
015	029, 030	U615	035	069, 070	U715
016	031, 032	U616	036	071, 072	U716
017	033, 034	U617	037	073, 074	U717
018	035, 036	U618	038	075, 076	U718
019	037, 038	U619	039	077, 078	U719
020	039, 040	U620	040	079, 080	U720
Backplane		Relay	Backplane		Relay
911		K800	921		K804
912		K801	922		K805
913		K802	923		K806
914		K803	924		K807

34931A Dual 4x8 Armature Matrix

The 34931A dual 4x8 armature matrix contains two matrices, each with 32 2-wire crosspoint latching armature relays organized in a 4- row by 8- column configuration. Every row and column are made up of two wires each, a high (H) and a low (L). Each crosspoint relay has a unique channel number representing the row and column that intersects to create the crosspoint. For example, channel 304 represent the crosspoint connection between row 3 and column 4 (all columns consisting of two digits). See the simplified schematic below.

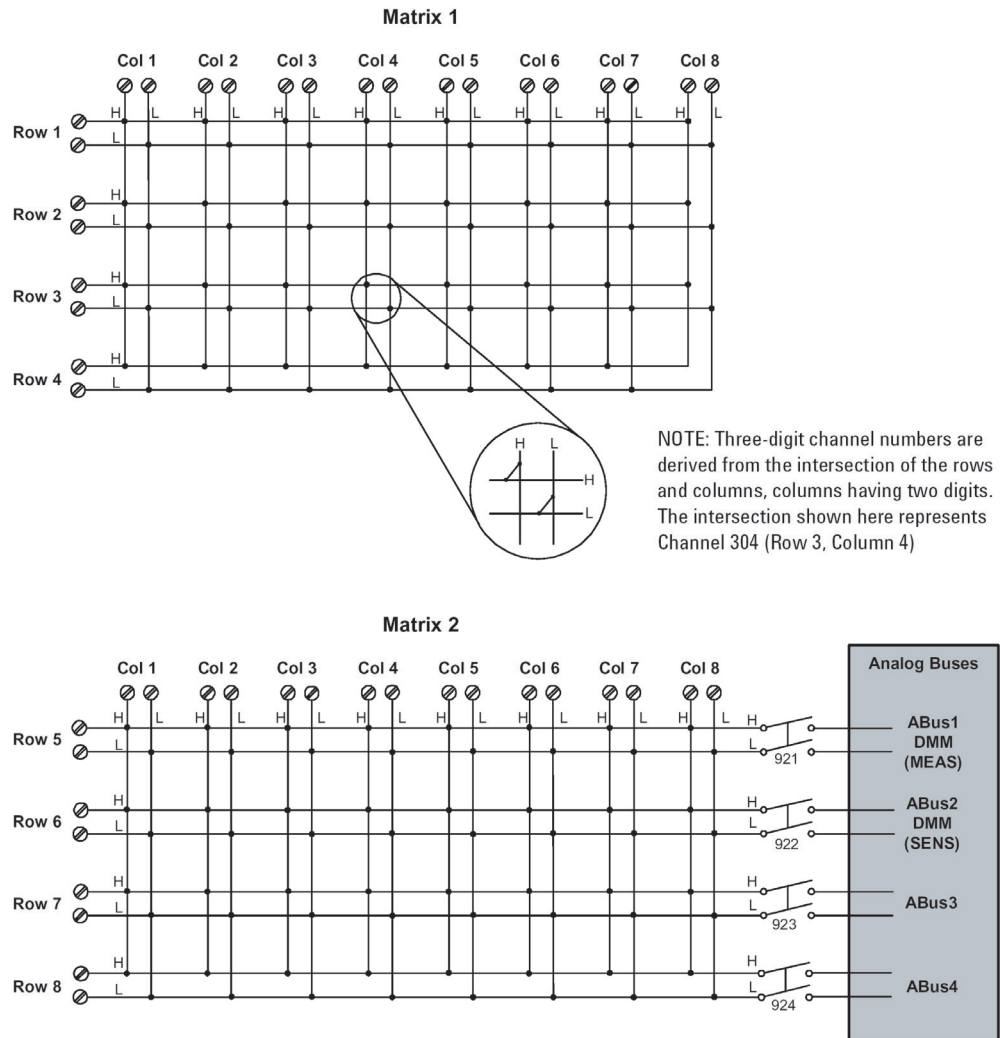

Matrix 1 and Matrix 2 are electrically separate from one another.

Matrix Relays: Armature latching. Analog Bus Relays: Armature non-latching.

For the 34931A, relay part numbers are given on [page 128](#) and the component locator is shown on [page 142](#). The table below shows the relationship of channel numbers to relay numbers.

Matrix 1		Matrix 2	
Channel	Relay	Channel	Relay
101	K7101	501	K8501
102	K7102	502	K8502
103	K7103	503	K8503
104	K7104	504	K8504
105	K7105	505	K8505
106	K7106	506	K8506
107	K7107	507	K8507
108	K7108	508	K8508
201	K7201	601	K8601
202	K7202	602	K8602
203	K7203	603	K8603
204	K7204	604	K8604
205	K7205	605	K8605
206	K7206	606	K8606
207	K7207	607	K8607
208	K7208	608	K8608
301	K7301	701	K8701
302	K7302	702	K8702
303	K7303	703	K8703
304	K7304	704	K8704
305	K7305	705	K8705
306	K7306	706	K8706
307	K7307	707	K8707
308	K7308	708	K8708
401	K7401	801	K8801
402	K7402	802	K8802
403	K7403	803	K8803
404	K7404	804	K8804
405	K7405	805	K8805
406	K7406	806	K8806
407	K7407	807	K8807
408	K7408	808	K8808
		Backplane	
		921	K921
		922	K922
		923	K923
		924	K924

34932A Dual 4x16 Armature Matrix

The 34932A dual 4x16 armature matrix contains two matrices, each with 64 2-wire crosspoint latching armature relays organized in a 4-row by 16-column configuration. Every row and column are made up of two wires each, a high (H) and a low (L). Each crosspoint relay has a unique channel number representing the row and column that intersect to create the crosspoint. For example, channel 315 represents the crosspoint connection between row 3 and column 15 (all columns consisting of two digits). See the simplified schematic below.

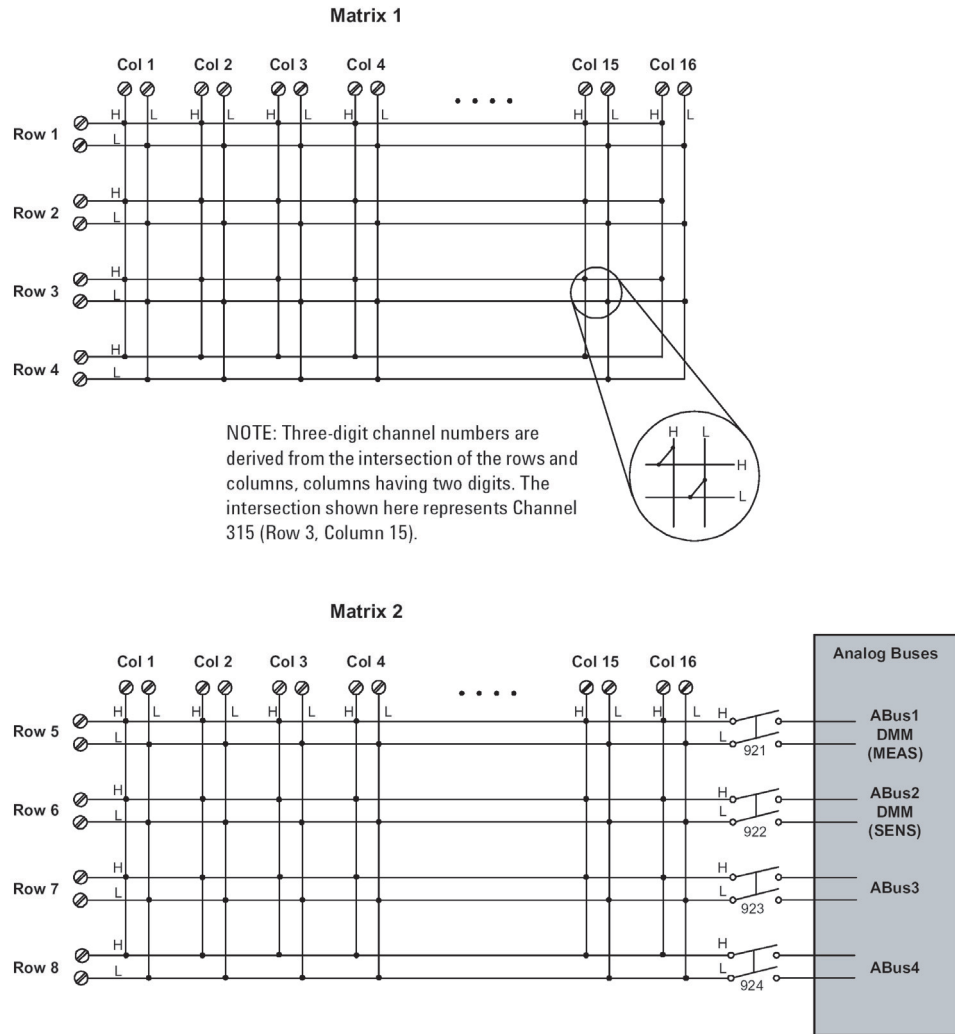

Matrix 1 and Matrix 2 are electrically separate from one another.

Matrix Relays: Armature latching. Analog Bus Relays: Armature non-latching

For the 34932A, relay part numbers are given on [page 129](#) and the component locator is shown on [page 143](#). The table below and on the next page shows the relationship of channel numbers to relay numbers.

Matrix 1		Matrix 2	
Channel	Relay	Channel	Relay
101	K7101	501	K8501
102	K7102	502	K8502
103	K7103	503	K8503
104	K7104	504	K8504
105	K7105	505	K8505
106	K7106	506	K8506
107	K7107	507	K8507
108	K7108	508	K8508
109	K7109	509	K8509
110	K7110	510	K8510
111	K7111	511	K8511
112	K7112	512	K8512
113	K7113	513	K8513
114	K7114	514	K8514
115	K7115	515	K8515
116	K7116	516	K8516
201	K7201	601	K8601
202	K7202	602	K8602
203	K7203	603	K8603
204	K7204	604	K8604
205	K7205	605	K8605
206	K7206	606	K8606
207	K7207	607	K8607
208	K7208	608	K8608
209	K7209	609	K8609
210	K7210	610	K8610
211	K7211	611	K8611
212	K7212	612	K8612
213	K7213	613	K8613
214	K7214	614	K8614
215	K7215	615	K8615
216	K7216	616	K8616

4 Troubleshooting and Diagnostics

Matrix 1		Matrix 2	
Channel	Relay	Channel	Relay
301	K7301	701	K8701
302	K7302	702	K8702
303	K7303	703	K8703
304	K7304	704	K8704
305	K7305	705	K8705
306	K7306	706	K8706
307	K7307	707	K8707
308	K7308	708	K8708
309	K7309	709	K8709
310	K7310	710	K8710
311	K7311	711	K8711
312	K7312	712	K8712
313	K7313	713	K8713
314	K7314	714	K8714
315	K7315	715	K8715
316	K7316	716	K8716
401	K7401	801	K8801
402	K7402	802	K8802
403	K7403	803	K8803
404	K7404	804	K8804
405	K7405	805	K8805
406	K7406	806	K8806
407	K7407	807	K8807
408	K7408	808	K8808
409	K7409	809	K8809
410	K7410	810	K8810
411	K7411	811	K8811
412	K7412	812	K8812
413	K7413	813	K8813
414	K7414	814	K8814
415	K7415	815	K8815
416	K7416	816	K8816
		Backplane	
		921	K921
		922	K922
		923	K923
		924	K924

34933A Dual/Quad 4x8 Reed Matrix

Using program commands or the front panel of the 34980A, you can configure the 34933A dual/quad 4x8 reed matrix module for differential (2-wire) mode or single-ended (1-wire) mode.

The 34933A module contains 100 Ω in-rush resistors that are used to protect the reed relays from reactive loads. If you have applications where in-rush resistors interfere with measurements, connections are provided on the terminal blocks for you to bypass the in-rush resistors that are located on the columns.

Two-Wire Mode

In 2-wire mode, the 34933A module contains two matrices, each with 32 2-wire crosspoint non-latching reed relays organized in a 4-row by 8-column configuration. Every row and column are made up of two wires each, a high (H) and a low (L). Each crosspoint relay has a unique channel number representing the row and column that intersect to create the crosspoint. For example, channel 308 represents the crosspoint connection between row 3 and column 08 (all columns consisting of two digits; in this case the digits are 08). See the simplified schematic on [page 108](#).

One-Wire Mode

In 1-wire mode, the 34933A module contains four matrices (1 through 4), each with 32 1-wire crosspoint non-latching reed relays organized in a 4-row by 8-column configuration. Every row and column has one wire each. Each crosspoint relay has a unique channel number representing the matrix, and the single-wire row and column that intersect to make the crosspoint. For example, channel 218 represents Matrix 2, row 1 and column 8. See the simplified schematic on [page 109](#).

34933A Two-Wire Mode

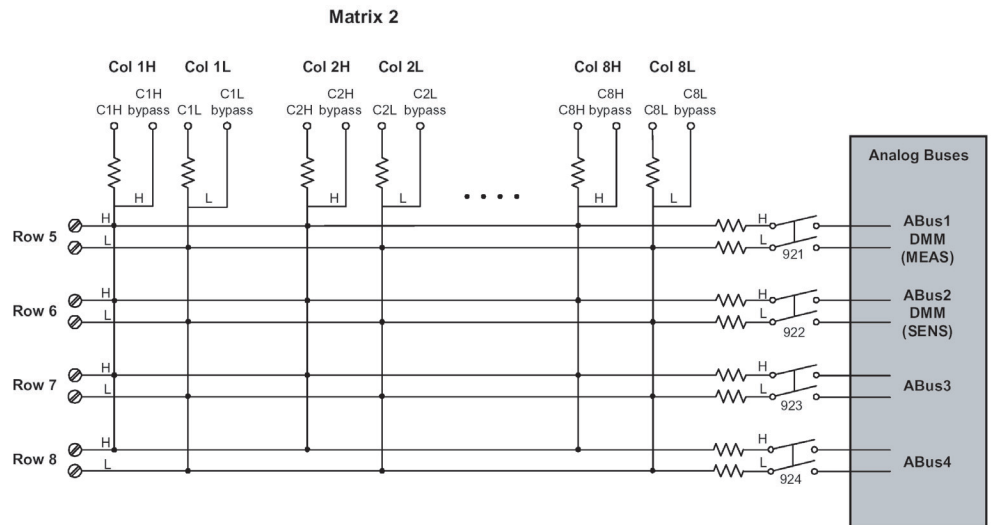
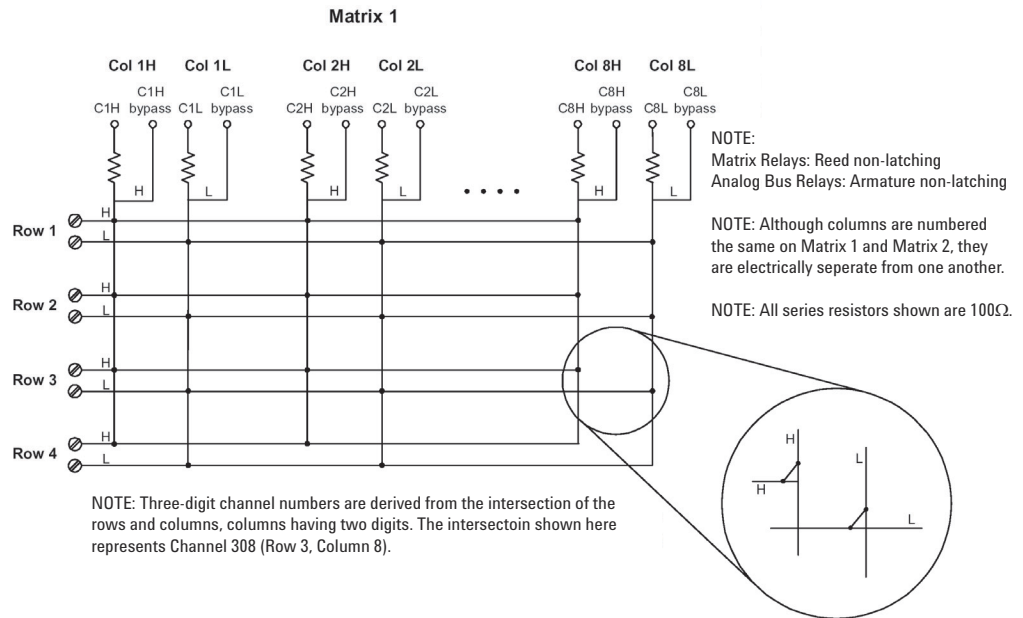

34933A One-Wire Mode

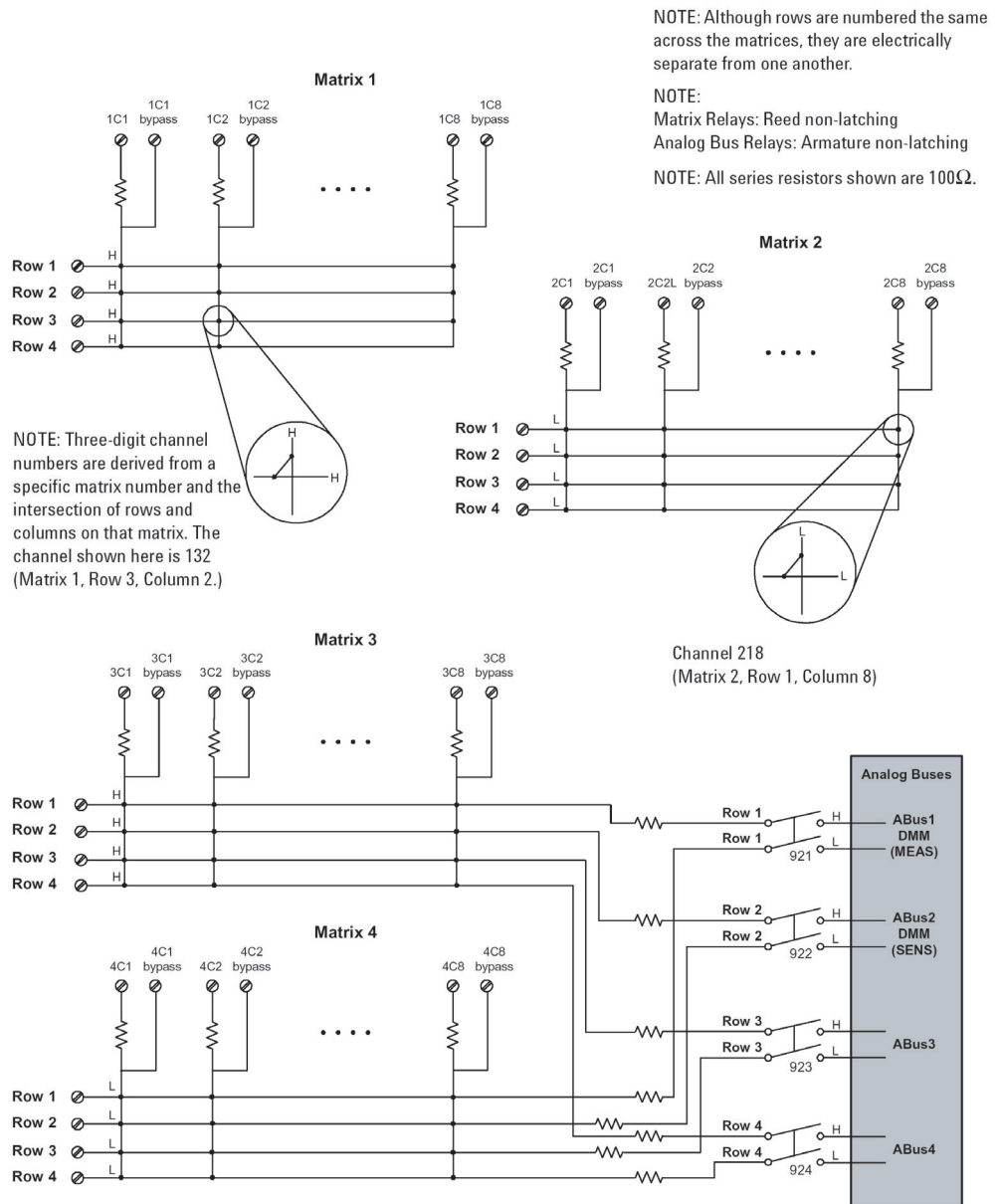

For the 34933A, relay part numbers are given on [page 130](#) and the component locator is shown on [page 144](#). The table on the next page shows the relationship of channel numbers to relay numbers.

4 Troubleshooting and Diagnostics

Matrix 1			Matrix 2		
2-Wire Channel	1-Wire Channel	Relay	2-Wire Channel	1-Wire Channel	Relay
101	111, 211	K505	501	311, 411	K605
102	112, 212	K508	502	312, 412	K608
103	113, 213	K507	503	313, 413	K607
104	114, 214	K506	504	314, 414	K606
105	115, 215	K504	505	315, 415	K604
106	116, 216	K503	506	316, 416	K603
107	117, 217	K502	507	317, 417	K602
108	118, 218	K501	508	318, 418	K601
201	121, 221	K505	601	321, 421	K605
202	122, 222	K508	602	322, 422	K608
203	123, 223	K507	603	323, 423	K607
204	124, 224	K506	604	324, 424	K606
205	125, 225	K504	605	325, 425	K604
206	126, 226	K503	606	326, 426	K603
207	127, 227	K502	607	327, 427	K602
208	128, 228	K501	608	328, 428	K601
301	131, 231	K505	701	331, 431	K605
302	132, 232	K508	702	332, 432	K608
303	133, 233	K507	703	333, 433	K607
304	134, 234	K506	704	334, 434	K606
305	135, 235	K504	705	335, 435	K604
306	136, 236	K503	706	336, 436	K603
307	137, 237	K502	707	337, 437	K602
308	138, 238	K501	708	338, 438	K601
401	141, 241	K505	801	341, 441	K605
402	142, 242	K508	802	342, 442	K608
403	143, 243	K507	803	343, 443	K607
404	144, 244	K506	804	344, 444	K606
405	145, 245	K504	805	345, 445	K604
406	146, 246	K503	806	346, 446	K603
407	147, 247	K502	807	347, 447	K602
408	148, 248	K501	808	348, 448	K601
			Backplane		
			921		K704
			922		K703
			923		K702
			924		K701

34937A 32-Channel GP Switch

The 34937A general-purpose switch module provides independent control of:

- Twenty-eight Form C (DPST) latching relays rated at 1 A
- Four Form A (SPST) latching relays rated at 5 A.

A simplified schematic is shown below.

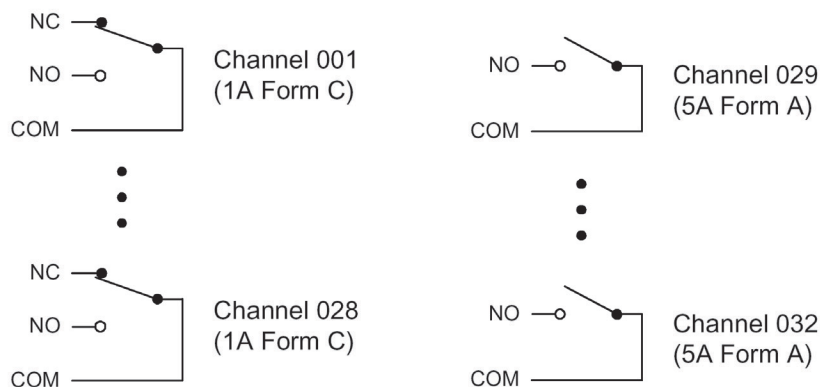

For the 34937A, relay part numbers are given on [page 130](#) and the component locator is shown on [page 145](#). The table below shows the relationship of channel numbers to relay numbers.

Bank 1		Bank 2	
Channel	Relay	Channel	Relay
001	K601	015	K615
002	K602	016	K616
003	K603	017	K617
004	K604	018	K618
005	K605	019	K619
006	K606	020	K620
007	K607	021	K621
008	K608	022	K622
009	K609	023	K623
010	K610	024	K624
011	K611	024	K625
012	K612	026	K626
013	K613	027	K627
Form A		Form A	
029	K629	031	K631
030	K630	032	K632

34938A 20-Channel High-Current GP Switch

The 34938A high-current GP switch module provides twenty 5 A Form A relays for general purpose switching needs.

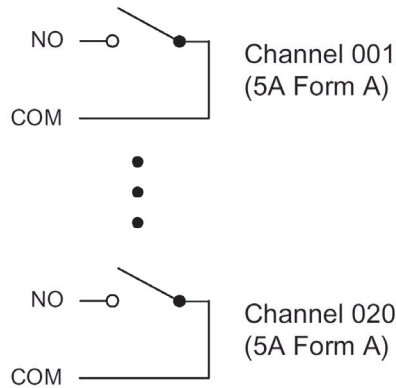

For the 34938A, relay part numbers are given on [page 130](#) and the component locator is shown on [page 146](#). The table below shows the relationship of channel numbers to relay numbers.

Bank 1		Bank 2	
Channel	Relay	Channel	Relay
001	K501	011	K511
002	K502	012	K512
003	K503	013	K513
004	K504	014	K514
005	K505	015	K515
006	K506	016	K516
007	K507	017	K517
008	K508	018	K518
009	K509	019	K519
010	K510	020	K520



5 Disassembly and Repair

Electrostatic Discharge (ESD) Precautions	114
Surface Mount Repair	114
Tools Required	114
Basic Disassembly	115
Power Supply Removal	116
Power Supply Disassembly	117
KOM Removal	118
Front Panel Removal	119
Front Panel Disassembly	120
DMM Removal	121
Backplane Removal	122



Electrostatic Discharge (ESD) Precautions

Almost all electrical components can be damaged by electrostatic discharge (ESD) during handling. Component damage can occur at electrostatic discharge voltages as low as 50 volts.

The following guidelines will help prevent ESD damage when servicing the instrument or one of the plug-in modules.

- Disassemble the instrument only in a static-free work area.
- Use a conductive work area to dissipate any static charge.
- Use a conductive wrist strap to dissipate static charge accumulation.
- Minimize handling.
- Keep replacement parts in their original static-free packaging.
- Remove all plastic, foam, vinyl, paper, and other static-generating materials from the immediate work area.
- Use only anti-static solder suckers.

Surface Mount Repair

Surface mount components should only be removed using soldering irons or desoldering stations expressly designed for surface mount components. Use of conventional solder removal equipment will almost always result in permanent damage to the printed circuit board.

Tools Required

The following tools are required for basic disassembly.

- T20 Torx driver
- 3/16" nut driver (for rear panel connectors)
- 9/32" nut driver (for GP-IB connector)
- #2 Pozidrive (for fan)

Basic Disassembly

Observe the electrostatic discharge precautions given on [page 114](#).

- 1 Remove the power cable from the unit. If attached, remove the analog bus connector.
 - a If desired, you may also remove the feet by lifting the tab on each foot and sliding the foot toward the rear of the instrument.
- 2 Remove all plug-in modules.
- 3 Using a T-20 Torx driver, loosen the five captive screws in the rear bezel and remove the bezel. The metal cover will now slide off.

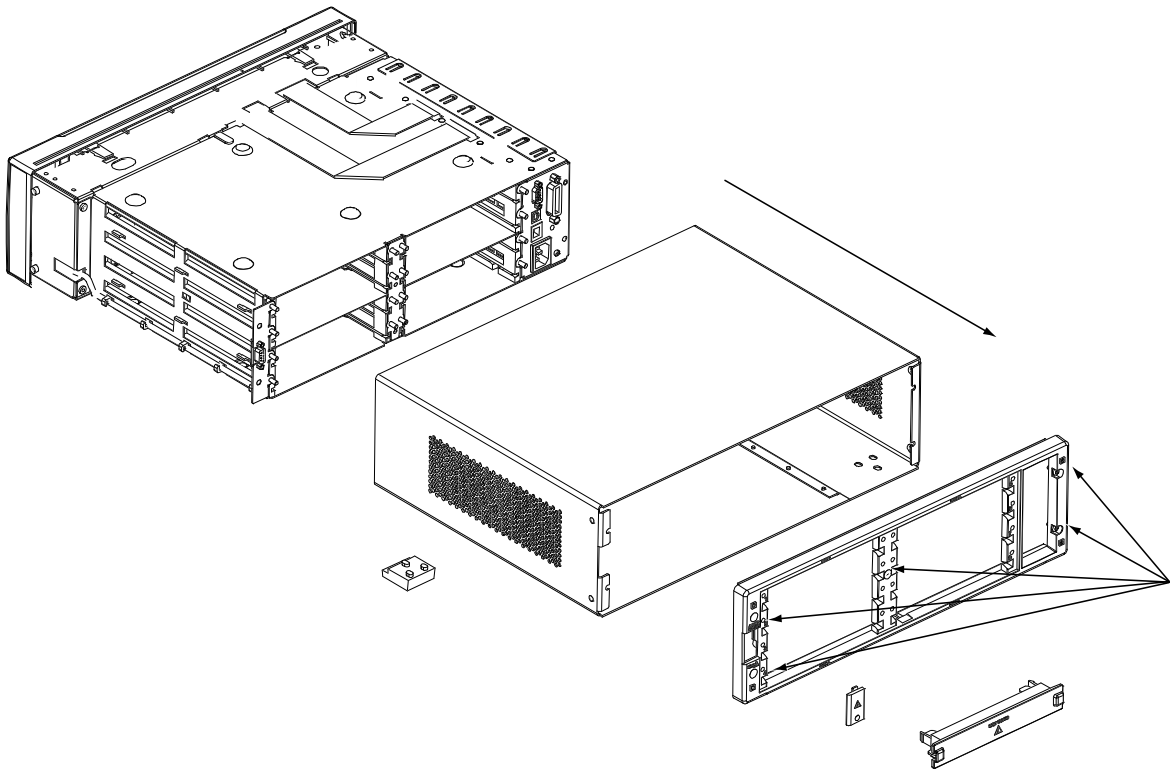

Power Supply Removal

- 1 Remove the two T20 Torx screws securing the power supply module.

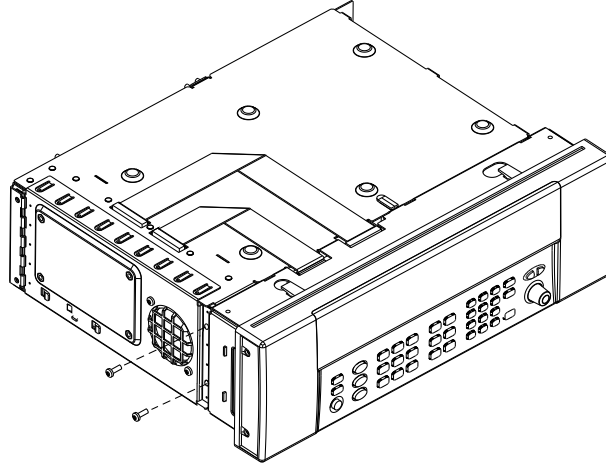

- 2 Swing the module out and disengage it from the sheet metal at the back.

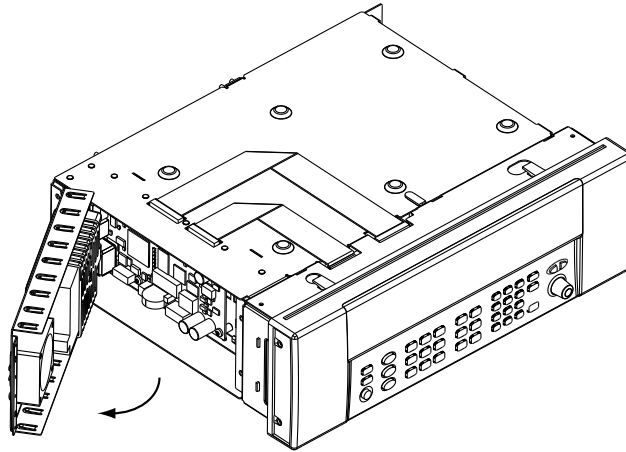

Note: For testing purposes, you can stand the power supply on end and insert it into slots in the mainframe as shown.

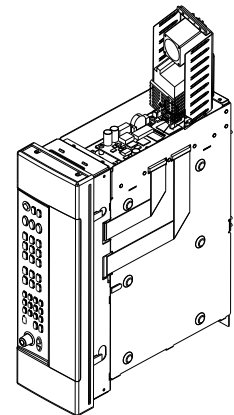

- 3 To completely remove the power supply, unplug the main power input (brown and blue) and the green/yellow ground wire from the power supply printed circuit board. Unplug the fan power and dc power from the KOM pc board.

Power Supply Disassembly

- 1 To disassembly the power supply, press the catch on the power supply shield and slide the shield to release it.

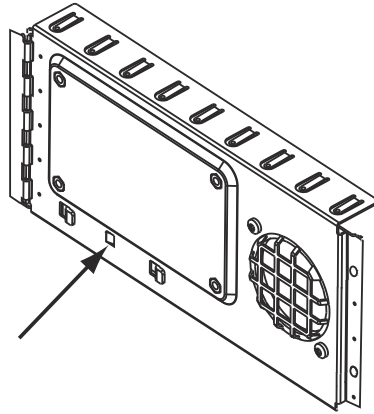

- 2 Remove the safety shield. Using a T20 Torx, remove the four screws holding the power supply printed circuit board to the sheet metal.

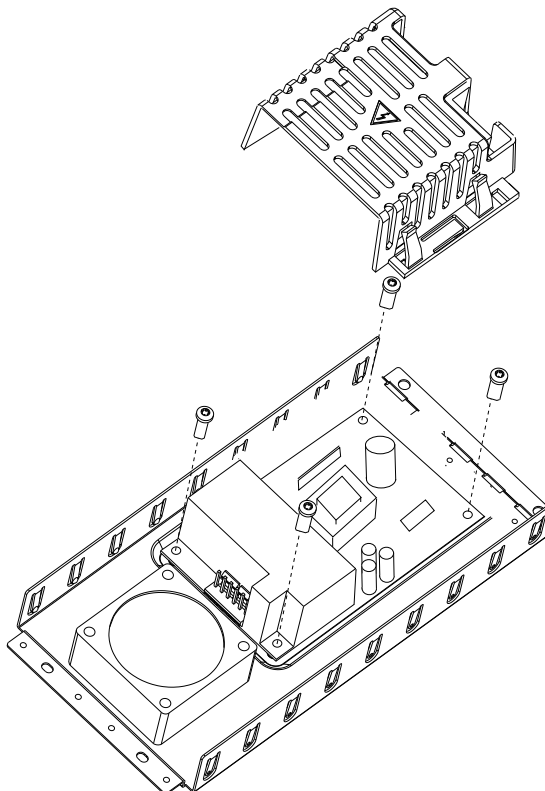

KOM Removal

- 1 Remove the power supply (see the procedure on [page 116](#)).
- 2 Disconnect the two ribbon cables on the top of the chassis.
- 3 Use a 3/16" nut driver to remove the nuts holding the Ext Trig DB9 connector on the rear panel. Use a 9/32" nut driver to remove the nuts holding the GP-IB connector on the rear panel.
- 4 Use a T20 Torx to remove the four screws holding the KOM printed circuit assembly to the mainframe. Lift out the assembly.

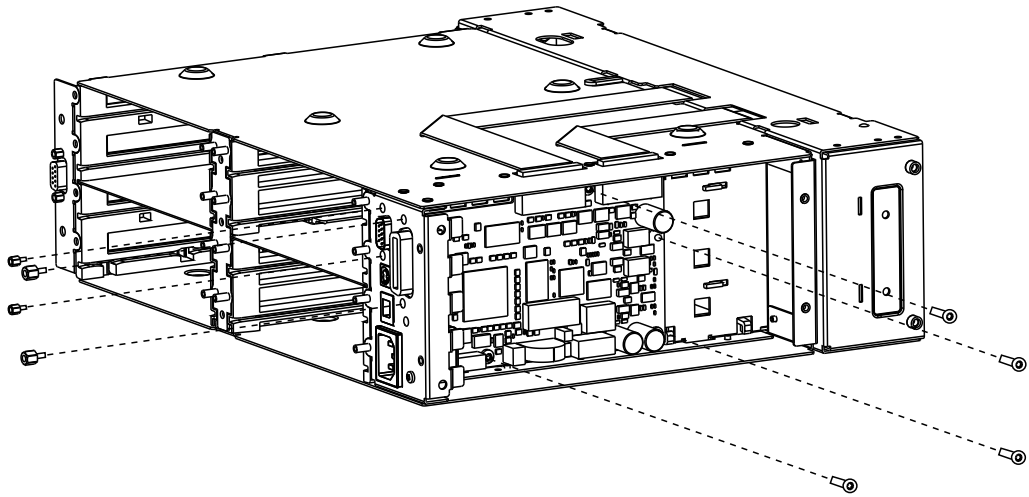

Front Panel Removal

- 1 Loosen the front panel assembly by lifting gently on the four plastic ears and moving the front panel off the mainframe. Stand the entire assembly on its side to make removal easier.
 - a Pull to unclip the ground connector from the mainframe.
 - b Swing the two clips securing the front panel connector ribbon cable to the front panel circuit board and unplug the connector.

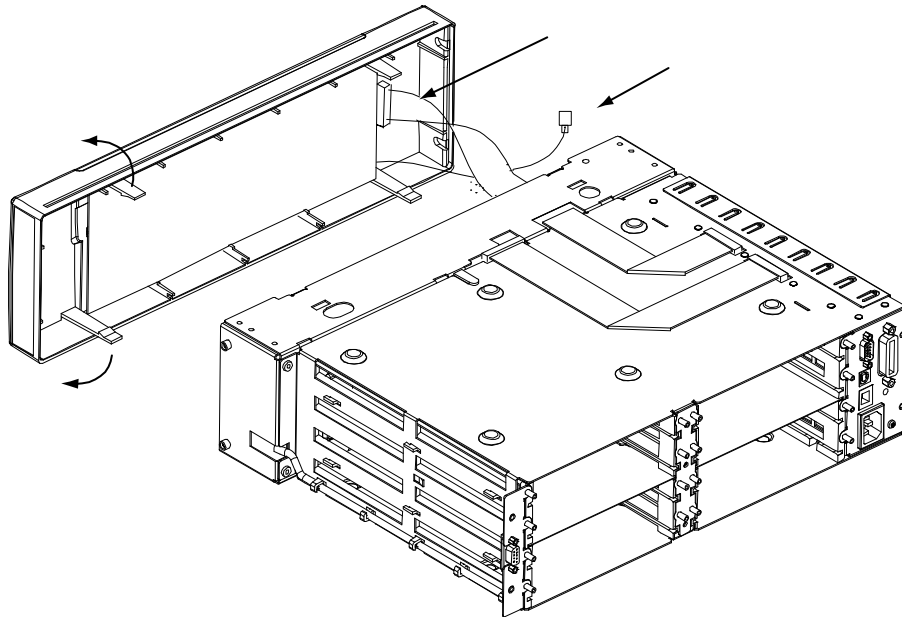

Front Panel Disassembly

- 1 Pull to remove the knob. Use a 7/16" nut driver to remove the nut from the knob shaft.
- 2 Remove the four T20 Torx screws from the circuit board and lift the circuit board out.

You can now lift out the keypad.

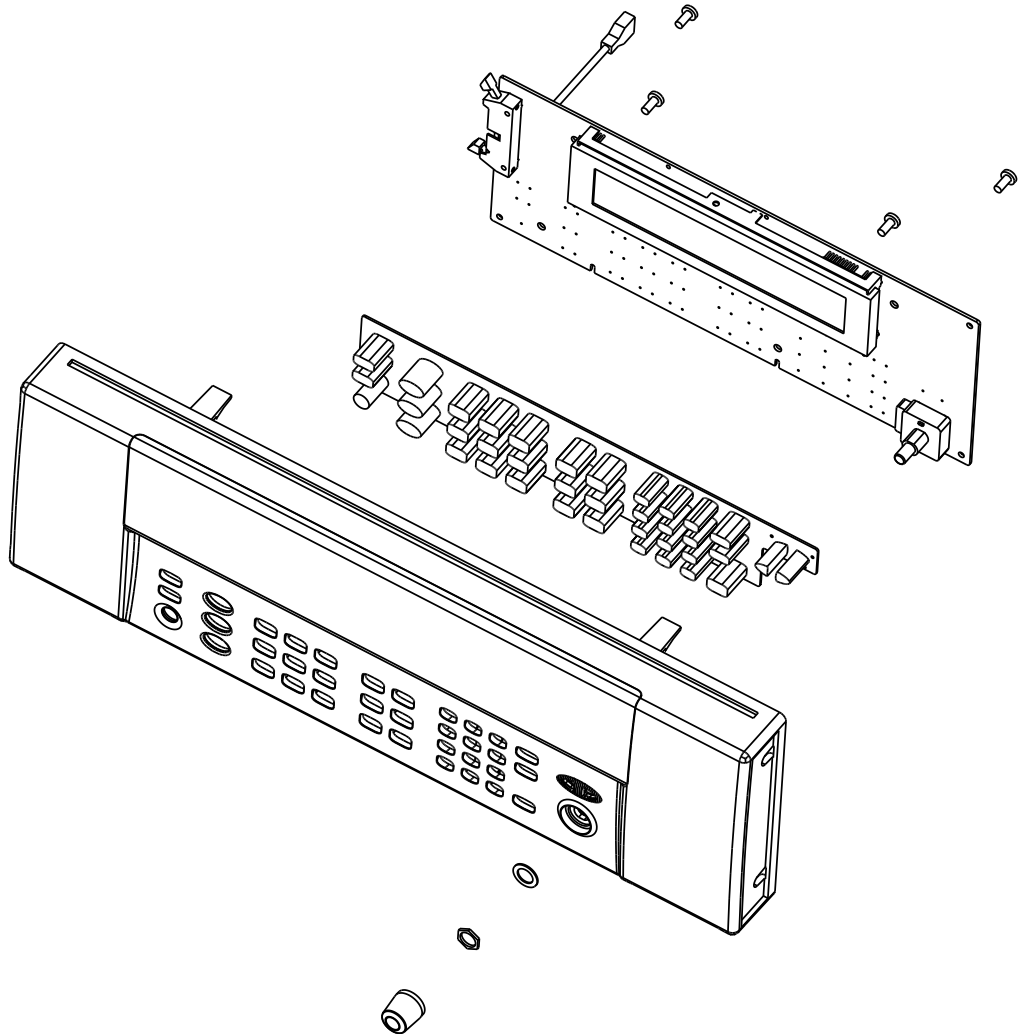

DMM Removal

- 1 To remove the DMM (if installed), remove the front panel (see the procedure on [page 119](#)).
- 2 Unplug the ribbon cable at the top of the DMM assembly.
- 3 Remove the two T20 Torx screws from the left front side of the mainframe.
- 4 Move the DMM assembly to the right and lift out.
- 5 Unplug the input cable from the backplane printed circuit board.

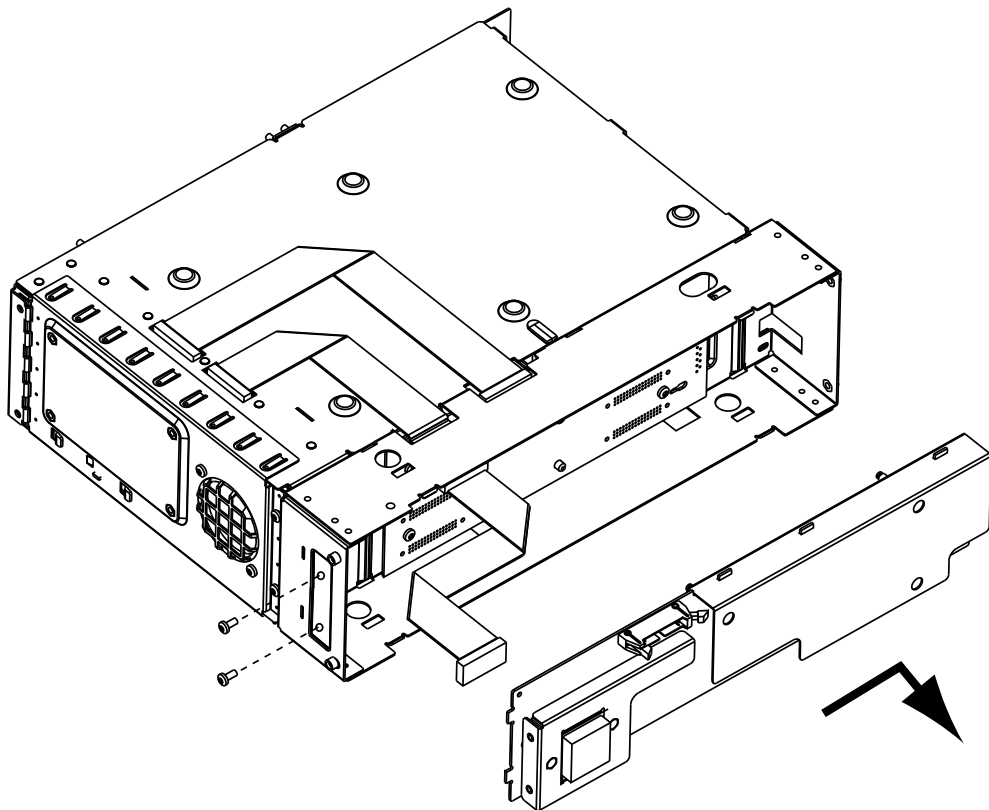

Backplane Removal

- 1 Remove the front panel (see the procedure on [page 119](#)) and the DMM (see the procedure on [page 121](#)).
- 2 Use a 3/16" nut driver to remove the rear panel Analog Bus DB9 connector. Unclip the connector cable from the mainframe.
- 3 Remove the five T20 Torx screws holding the backplane assembly to the chassis and lift the printed circuit assembly out.

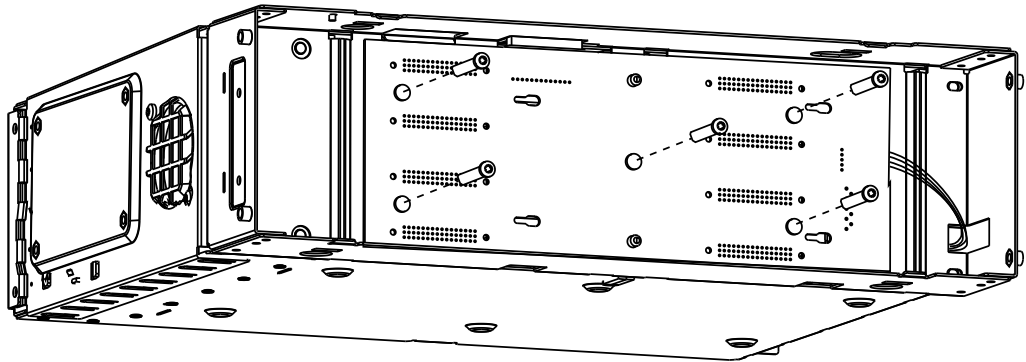



6 Replaceable Parts

To Order Replaceable Parts	124
Backdating and Part Changes	124
Mainframe Replaceable Parts	125
34921A Replaceable Parts	126
34922A Replaceable Parts	126
34923A Replaceable Parts	127
34924A Replaceable Parts	127
34925A Replaceable Parts	127
34931A Replaceable Parts	128
34932A Replaceable Parts	129
34933A Replaceable Parts	130
34937A Replaceable Parts	130
34938A Replaceable Parts	130
Vendor Addresses	131



Replaceable Parts

This section contains information for ordering replacement parts for your instrument. Parts are listed in alphanumeric order according to their reference designators. The parts lists include a brief description of each part with applicable Agilent part number.

To Order Replaceable Parts

You can order replaceable parts from Agilent using the Agilent part number. Note that only field-replaceable parts are listed in this service guide. Parts not listed here are not field replaceable and assembly replacement is recommended. To order replaceable parts from Agilent, do the following:

- 1 Contact your nearest Agilent Sales Office or Service Center.
- 2 Identify the parts by the Agilent part number shown in the replaceable parts list.
- 3 Provide the instrument model number and serial number.

Backdating and Part Changes

Always refer to Chapter 7, “Backdating” before attempting repair or before ordering replaceable parts. Parts changes, if any, are documented in the backdating chapter.

Mainframe Replaceable Parts

Refer to the disassembly drawings beginning on [page 115](#).

Agilent Part Number	Description
34980-66503	PCA - backplane
34980-66501	PCA - KOM and Power Supply
34980-67601	Line Filter Assembly
349980-61601	Cable, KOM to Backplane
34980-61604	Cable, front panel to KOM and DMM
34980-61606	Cable, Power Supply
34980-61607	Cable, ground green/yellow
0950-4603	Power Supply Module
34980-48001	Keypad
34980-48307	Front Panel
34980-66502	PCA - Front Panel
34980-49301	Window
34970-87401	Knob
34980-04104	Mainframe Cover, sheet metal
34980-48301	Rear Bezel
5041-9167	Foot
34980-48305	Cover, Analog Output
34980-48304	Cover, Slot
34980-66504	PCA, DMM
34980-68501	Fan Assembly

34921A Replaceable Parts

A component locator is shown on [page 136](#).

Component Locator	Agilent P/N	Description	Vendor	Vendor P/N
F1041, F1042, F1043, F1044	2110-0043	FUSE 1.5A 250V NTD FE UL-LST	Littelfuse	031201.5
K601, K602, K603, K604, K605, K606, K607, K608, K609, K610, K611, K612, K613, K614, K615, K616, K617, K618, K619, K620, K721, K722, K723, K724, K725, K726, K727, K728, K729, K730, K731, K732, K733, K734, K735, K736, K737, K738, K739, K740, K841, K842, K843, K844, K841S, K842S, K843S, K844S	0490-1896	RELAY 2C 3VDC-COIL 2A 30VDC	Omron	G6SU-2-DC3
K911, K912, K913, K914, K921, K922, K923, K924, K931	0490-1954	RELAY 2C 12VDC-COIL 2A 250VAC	Omron	G6S-2-DC12

34922A Replaceable Parts

A component locator is shown on [page 137](#).

Component Locator	Agilent P/N	Description	Vendor	Vendor P/N
K601, K602, K603, K604, K605, K606, K607, K608, K609, K610, K611, K612, K613, K614, K615, K616, K617, K618, K619, K620, K621, K622, K623, K624, K625, K626, K627, K628, K629, K630, K631, K632, K633, K634, K635, K736, K737, K738, K739, K740, K741, K742, K743, K744, K745, K746, K747, K748, K749, K750, K751, K752, K753, K754, K755, K756, K757, K758, K759, K760, K761, K762, K763, K764, K765, K766, K767, K768, K769, K770	0490-1896	RELAY 2C 3VDC-COIL 2A 30VDC	Omron	G6SU-2-DC3
K811, K812, K813, K814, K821, K822, K823, K824	0490-1954	RELAY 2C 12VDC-COIL 2A 250VAC	Omron	G6S-2-DC12

34923A Replaceable Parts

A component locator is shown on [page 138](#).

Component Locator	Agilent P/N	Description	Vendor	Vendor P/N
K401, K402, K403, K404, K405, K501, K502, K503, K504, K505	0490-2746	RLY-DRY-RD-1A-8 PC BUNDLE 0.5A 12V 300V	Coto	9000-0311
K609, K611, K612, K613, K614, K621, K622, K623, K624	0490-1954	RELAY 2C 12VDC-COIL 2A 250VAC	Omron	G6S-2-DC12

34924A Replaceable Parts

A component locator is shown on [page 139](#).

Component Locator	Agilent P/N	Description	Vendor	Vendor P/N
K401, K402, K403, K404, K405, K406, K407, K408, K409, K501, K502, K503, K504, K505, K506, K507, K508, K509	0490-2746	RLY-DRY-RD-1A-8 PC BUNDLE 0.5A 12V 300V	Coto	9000-0311
K611, K612, K613, K614, K621, K622, K623, K624	0490-1954	RELAY 2C 12VDC-COIL 2A 250VAC	Omron	G6S-2-DC12

34925A Replaceable Parts

Component locators begin on [page 140](#).

Component Locator	Agilent P/N	Description	Vendor	Vendor P/N
U601, U602, U603, U604, U605, U606, U607, U608, U609, U610, U611, U612, U613, U614, U615, U616, U617, U618, U619, U620, U701, U702, U703, U704, U705, U706, U707, U708, U709, U710, U711, U712, U713, U714, U715, U716, U717, U718, U719, U720	1990-3295	SOLID STATE RELAY IF 50mA-MAX BVR 3V SMT	Matsushita	AQW227NA
K800, K801, K802, K803, K804, K805, K806, K807	0490-1954	RELAY 2C 12VDC-COIL 2A 250VAC	Omron	G6S-2-DC12

34931A Replaceable Parts

A component locator is shown on [page 142](#).

Component Locator	Agilent P/N	Description	Vendor	Vendor P/N
K7101, K7102, K7103, K7104, K7105, K7106, K7107, K7108, K7201, K7202, K7203, K7204, K7205, K7206, K7207, K7208, K7301, K7302, K7303, K7304, K7305, K7306, K7307, K7308, K7401, K7402, K7403, K7404, K7405, K7406, K7407, K7408, K8501, K8502, K8503, K8504, K8505, K8506, K8507, K8508, K8601, K8602, K8603, K8604, K8605, K8606, K8607, K8608, K8701, K8702, K8703, K8704, K8705, K8706, K8707, K8708, K8801, K8802, K8803, K8804, K8805, K8806, K8807, K8808	0490-1896	RELAY 2C 3VDC-COIL 2A 30VDC	Omron	G6SU-2-DC3
K921, K922, K923, K924	0490-1954	RELAY 2C 12VDC-COIL 2A 250VAC	Omron	G6S-2-DC12

34932A Replaceable Parts

A component locator is shown on [page 143](#).

Component Locator	Agilent P/N	Description	Vendor	Vendor P/N
K7101, K7102, K7103, K7104, K7105, K7106, K7107, K7108, K7109, K7110, K7111, K7112, K7113, K7114, K7115, K7116, K7201, K7202, K7203, K7204, K7205, K7206, K7207, K7208, K7209, K7210, K7211, K7212, K7213, K7214, K7215, K7216, K7301, K7302, K7303, K7304, K7305, K7306, K7307, K7308, K7309, K7310, K7311, K7312, K7313, K7314, K7315, K7316, K7401, K7402, K7403, K7404, K7405, K7406, K7407, K7408, K7409, K7410, K7411, K7412, K7413, K7414, K7415, K7416, K8501, K8502, K8503, K8504, K8505, K8506, K8507, K8508, K8509, K8510, K8511, K8512, K8513, K8514, K8515, K8516, K8601, K8602, K8603, K8604, K8605, K8606, K8607, K8608, K8609, K8610, K8611, K8612, K8613, K8614, K8615, K8616, K8701, K8702, K8703, K8704, K8705, K8706, K8707, K8708, K8709, K8710, K8711, K8712, K8713, K8714, K8715, K8716, K8801, K8802, K8803, K8804, K8805, K8806, K8807, K8808, K8809, K8810, K8811, K8812, K8813, K8814, K8815, K8816	0490-1896	RELAY 2C 3VDC-COIL 2A 30VDC	Omron	G6SU-2-DC3
K921, K922, K923, K924	0490-1954	RELAY 2C 12VDC-COIL 2A 250VAC	Omron	G6S-2-DC12

34933A Replaceable Parts

A component locator is shown on [page 144](#).

Component Locator	Agilent P/N	Description	Vendor	Vendor P/N
K501, K502, K503, K504, K505, K506, K507, K508, K601, K602, K603, K604, K605, K606, K607, K608	0490-2746	RLY-DRY-RD-1A-8 PC BUNDLE 0.5A 12V 300V	Coto	9000-0311
K921, K922, K923, K924	0490-1954	RELAY 2C 12VDC-COIL 2A 250VAC	Omron	G6S-2-DC12

34937A Replaceable Parts

A component locator is shown on [page 145](#).

Component Locator	Agilent P/N	Description	Vendor	Vendor P/N
K601, K602, K603, K604, K605, K606, K607, K608, K609, K610, K611, K612, K613, K614, K615, K616, K617, K618, K619, K620, K621, K622, K623, K624, K625, K626, K627, K628	0490-1896	RELAY 2C 3VDC-COIL 2A 30VDC	Omron	G6SU-2-DC3
K629, K630, K631, K632	0490-2731	RELAY 1A 9VDC-COIL 5A 30VDC THRU HOLE	Matsushita	DSP1A-L2-D C9V-F

34938A Replaceable Parts

A component locator is shown on [page 146](#).

Component Locator	Agilent P/N	Description	Vendor	Vendor P/N
K501, K502, K503, K504, K505, K506, K507, K508, K509, K510, K511, K512, K513, K514, K515, K516, K517, K518, K519, K520	0490-2731	RELAY 1A 9VDC-COIL 5A 30VDC THRU HOLE	Matsushita	DSP1A-L2- DC9V-F

Vendor Addresses

Agilent Technologies, Inc.
3501 Stevens Creek Blvd
Santa Clara, CA 95052 U.S.A.

Omron Electronics LLC
55 East Commerce Drive
Schaumburg, IL 60173-5302 U.S.A.

Coto Technology
55 DuPont Drive
Providence, RI 02907 U.S.A

Matsushita
c/o Panasonic Electric Works Corporation of America
629 Central Avenue
New Providence, NJ 07974 U.S.A

Littelfuse
800 East Northwest Highway
Des Plaines, IL 60016 U.S.A

6 Replaceable Parts



7 Backdating



Backdating

This chapter contains information necessary to adapt this manual to instruments and assemblies not directly covered by the current content.

There are no backdated assemblies at the time of this printing.



8 Diagrams

34921A Component Locator	136
34922A Component Locator	137
34923A Component Locator	138
34924A Component Locator	139
34925A Component Locator (Top)	140
34925A Component Locator (Bottom)	141
34931A Component Locator	142
34932A Component Locator	143
34933A Component Locator	144
34937A Component Locator	145
34938A Component Locator	146



34921A Component Locator

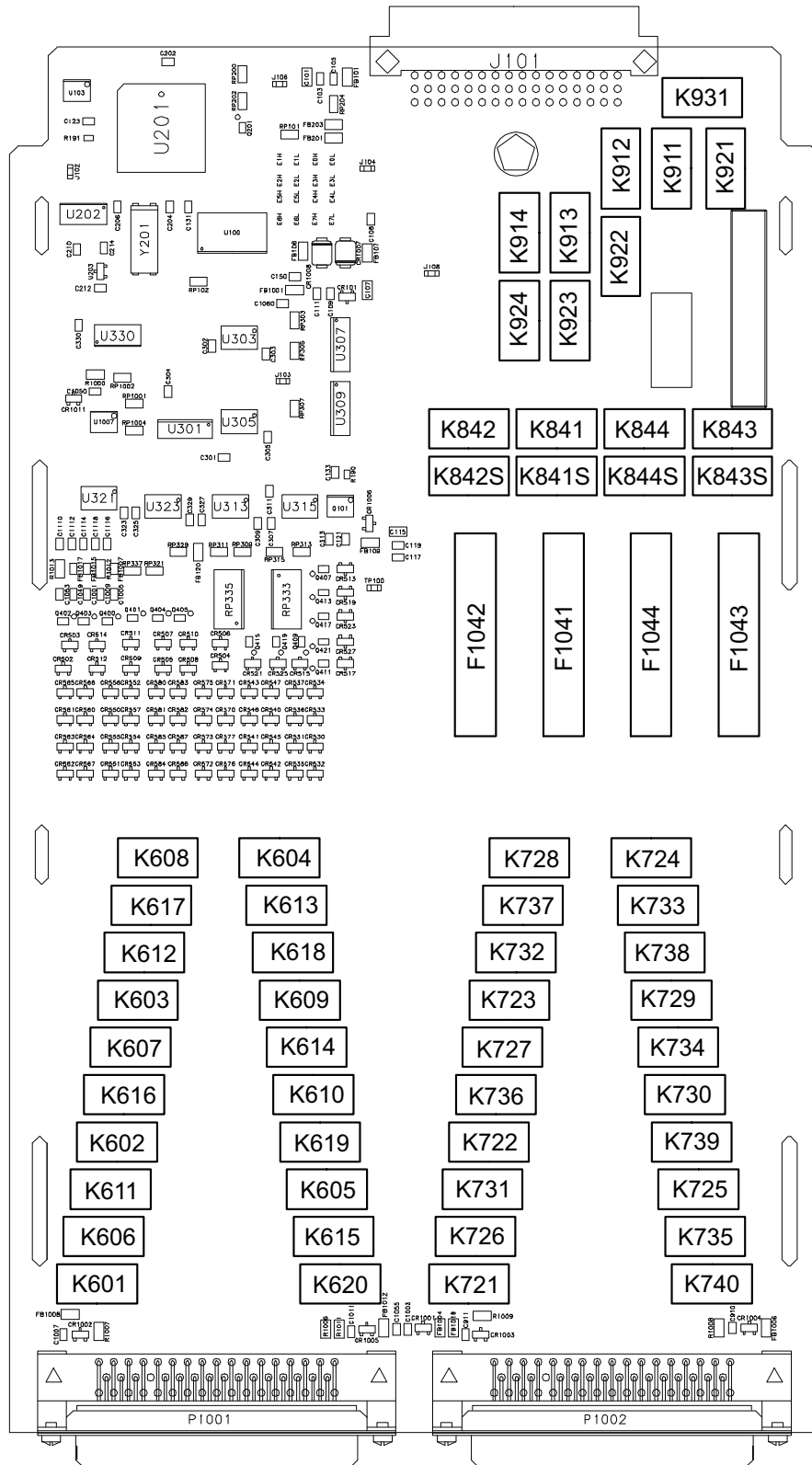

34922A Component Locator

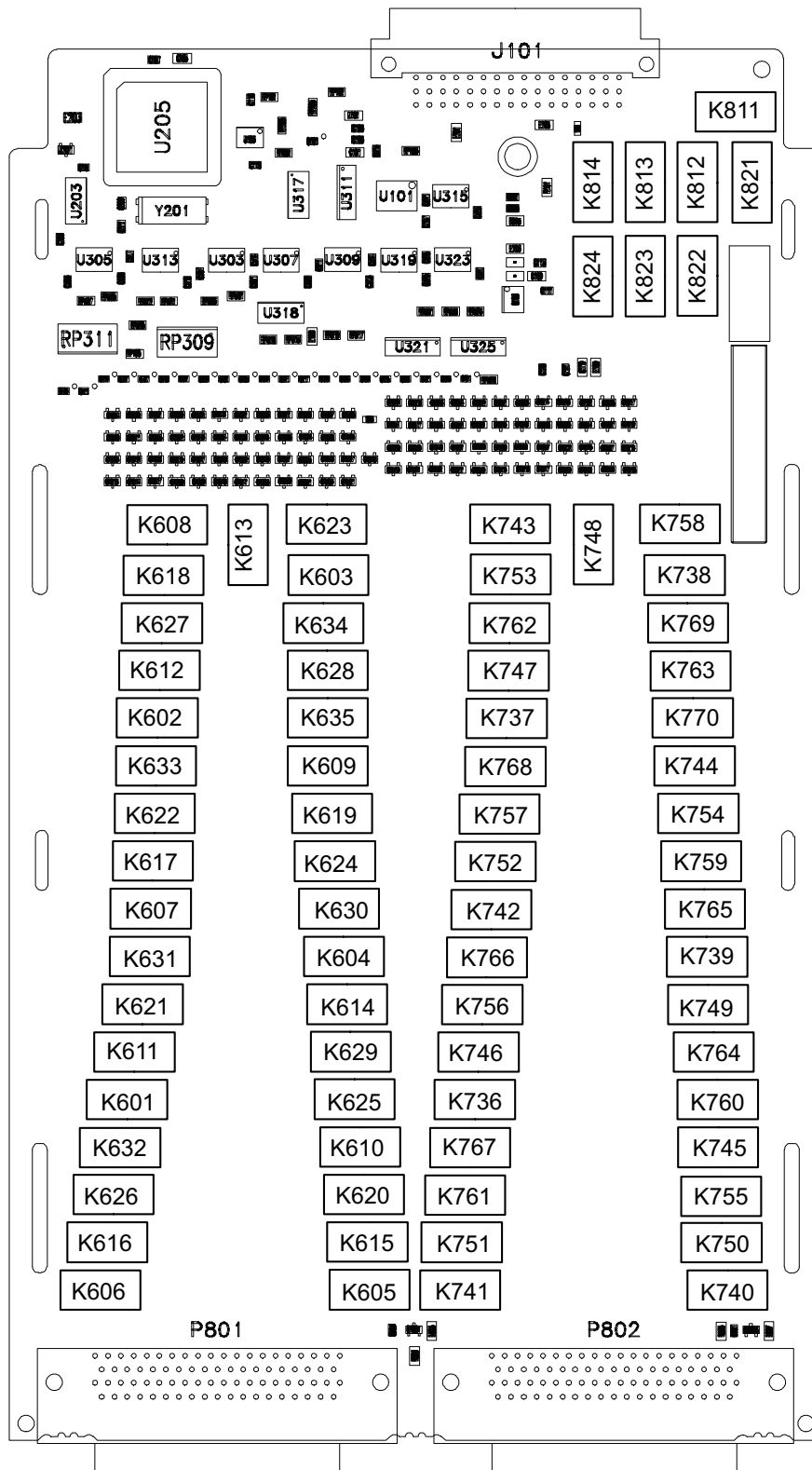

34923A Component Locator

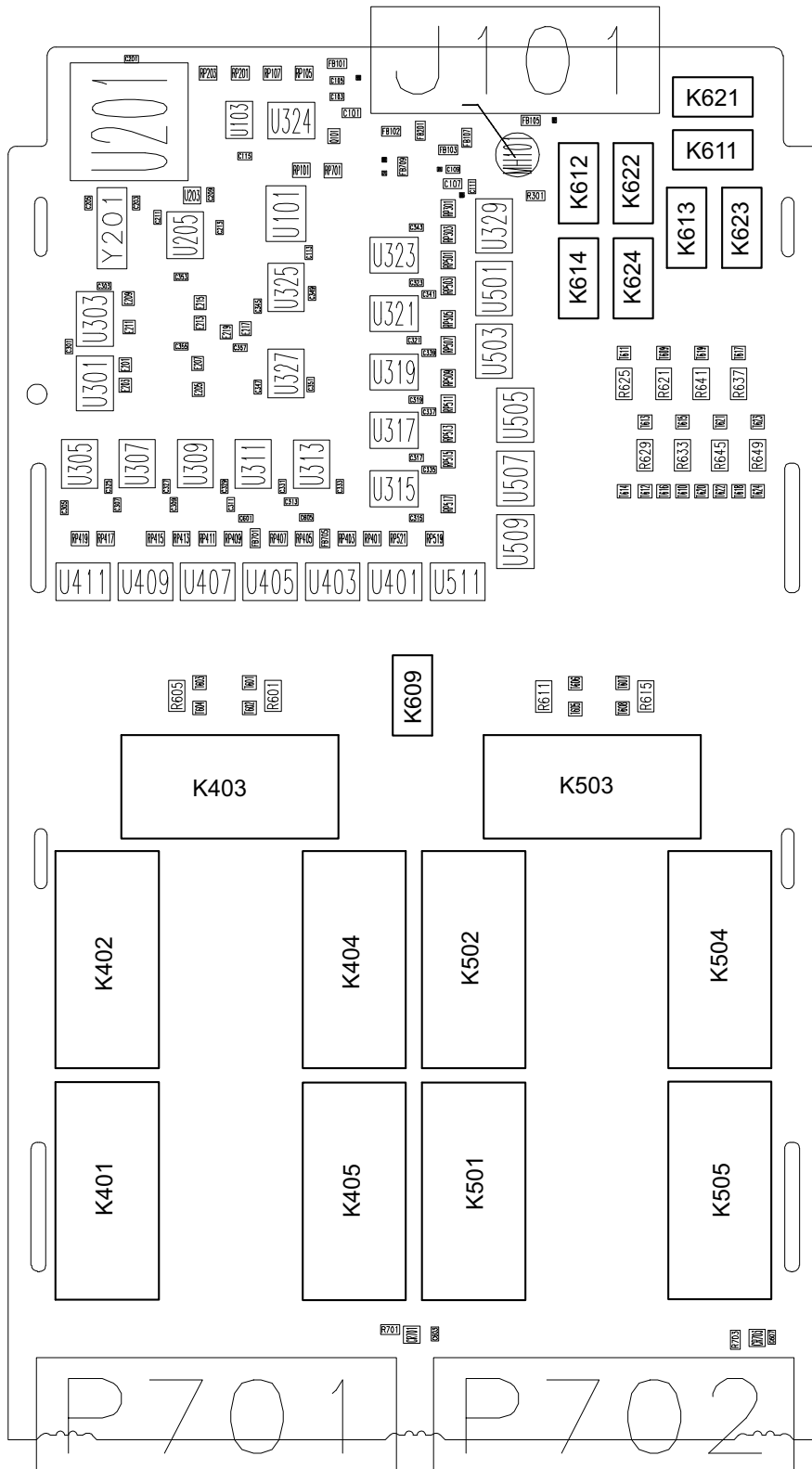

34924A Component Locator

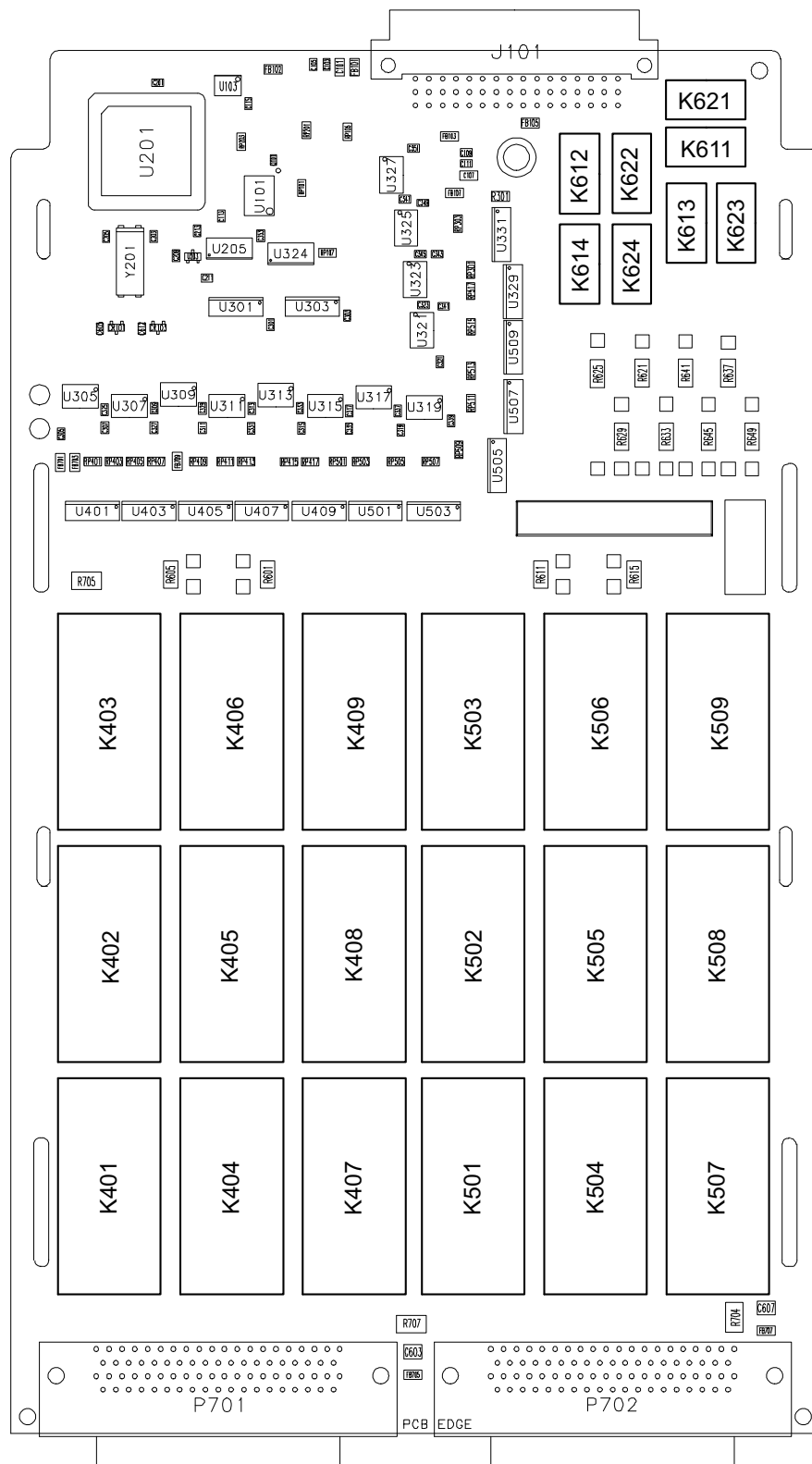

34925A Component Locator (Top)

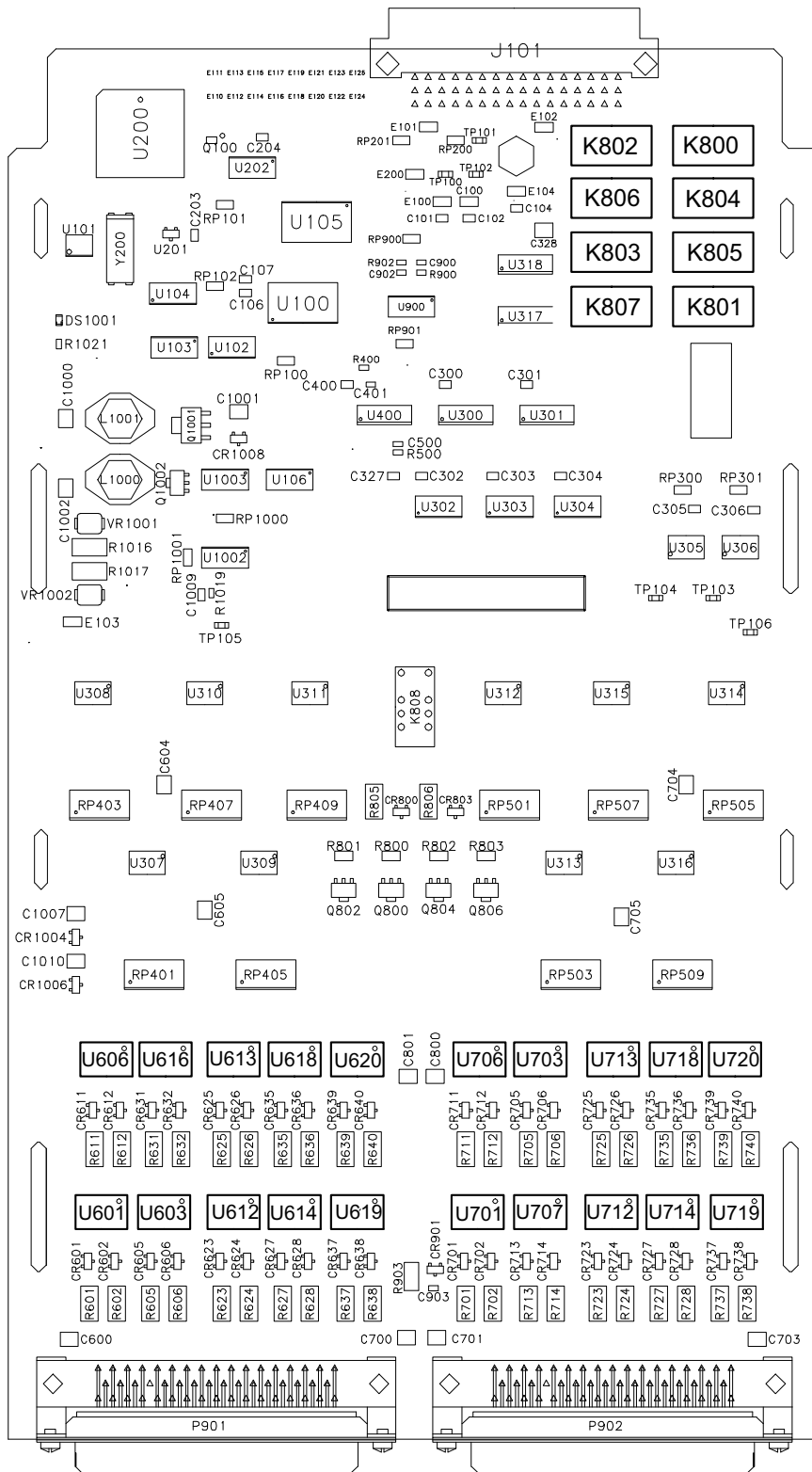

34931A Component Locator

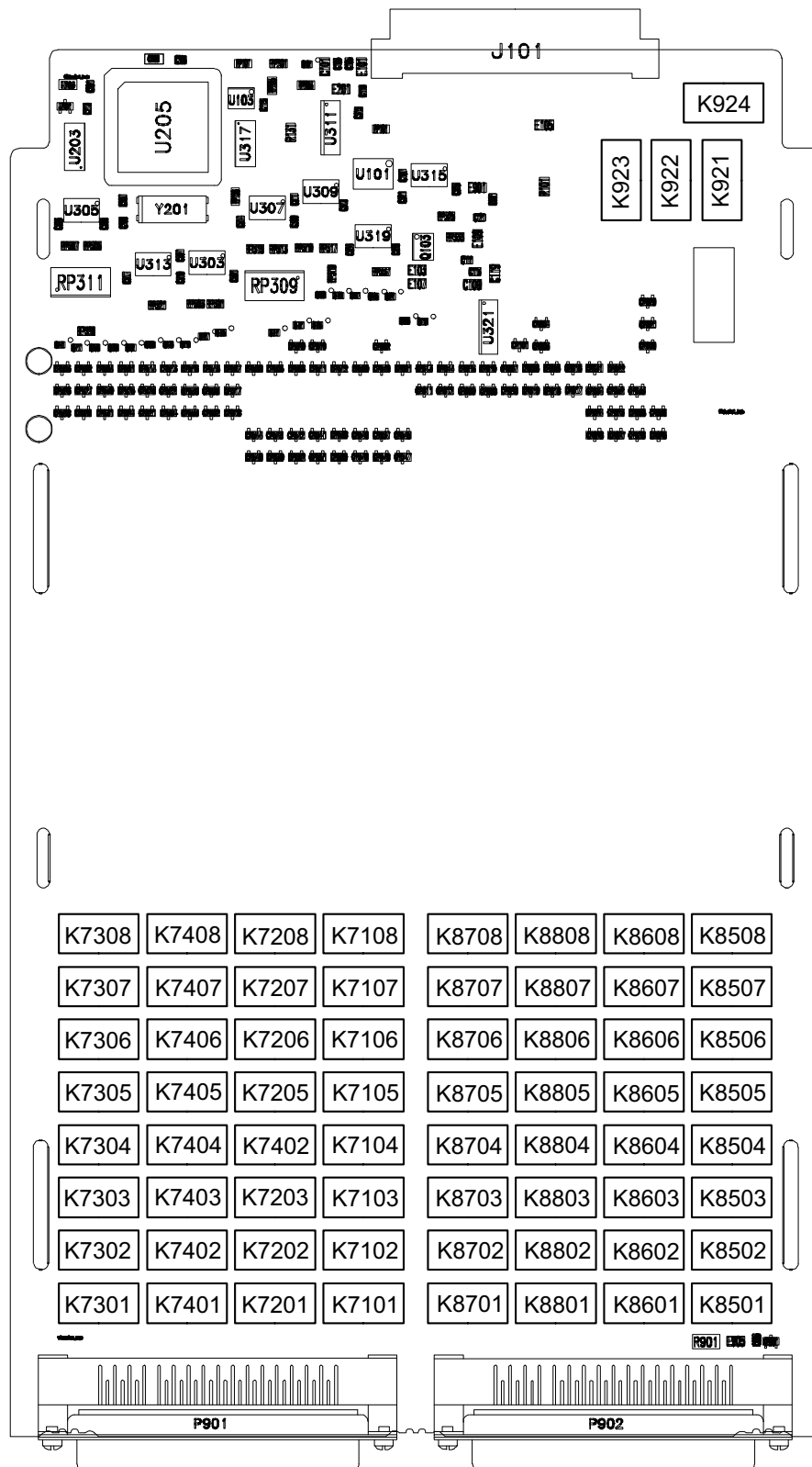

34932A Component Locator

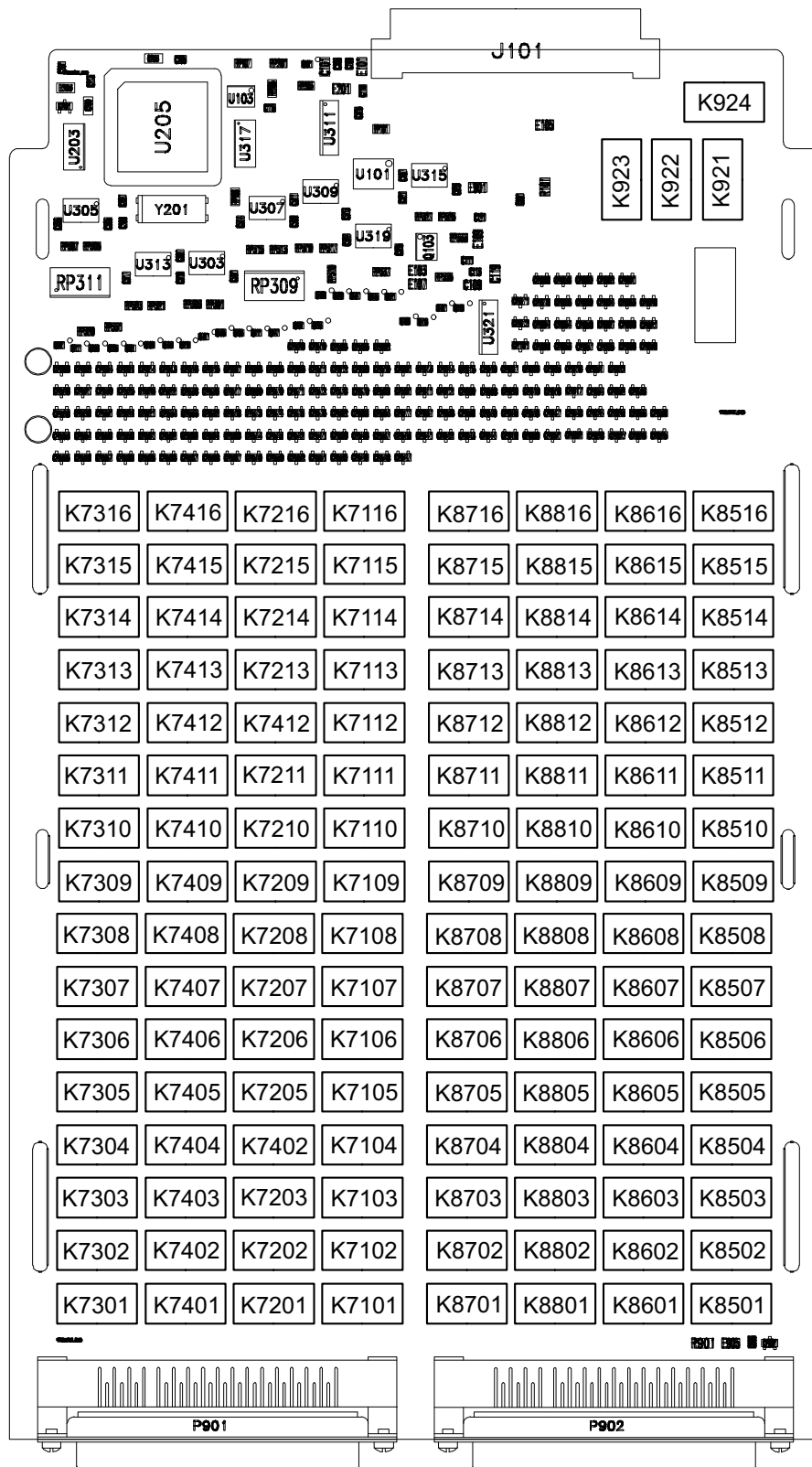

34933A Component Locator

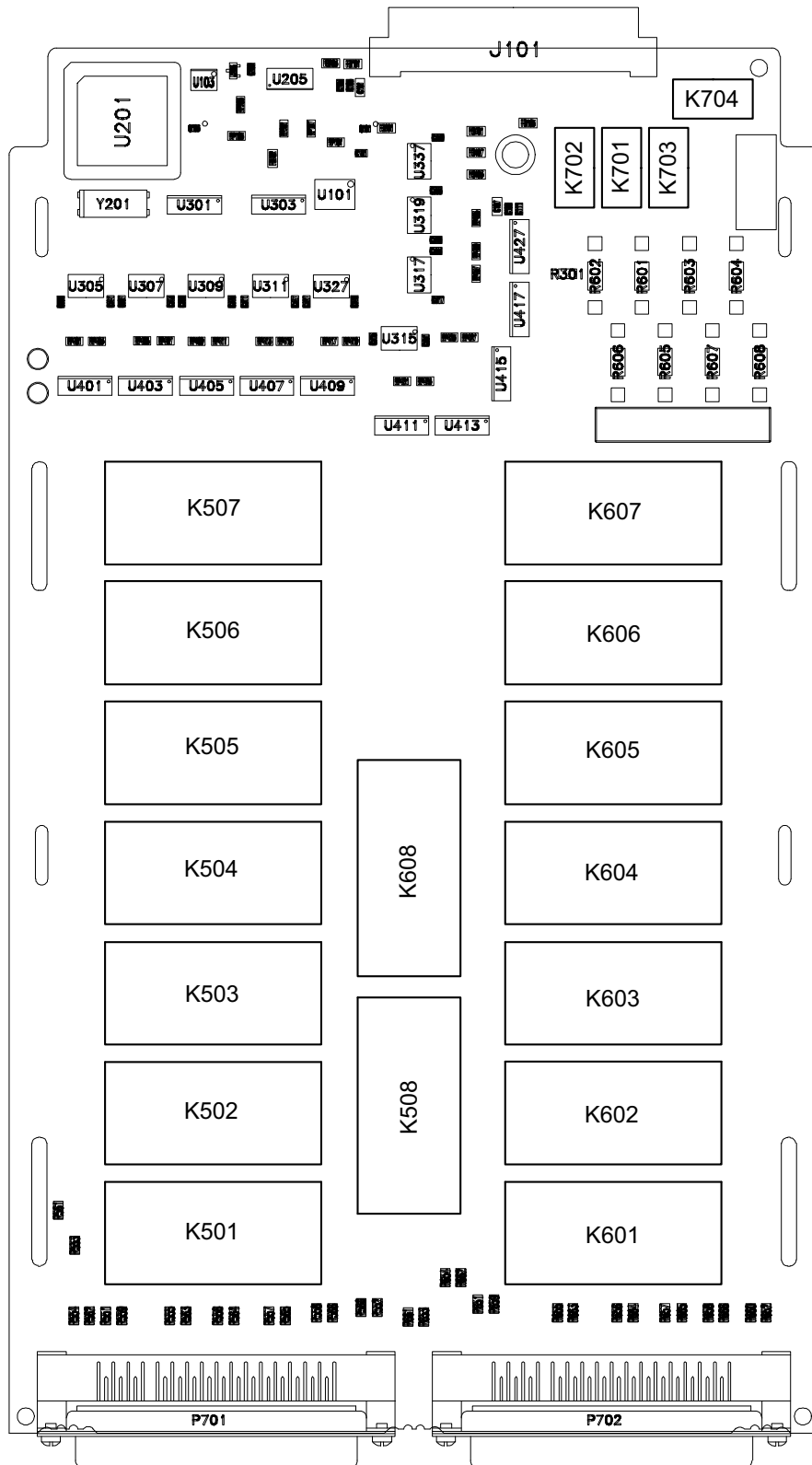

34937A Component Locator

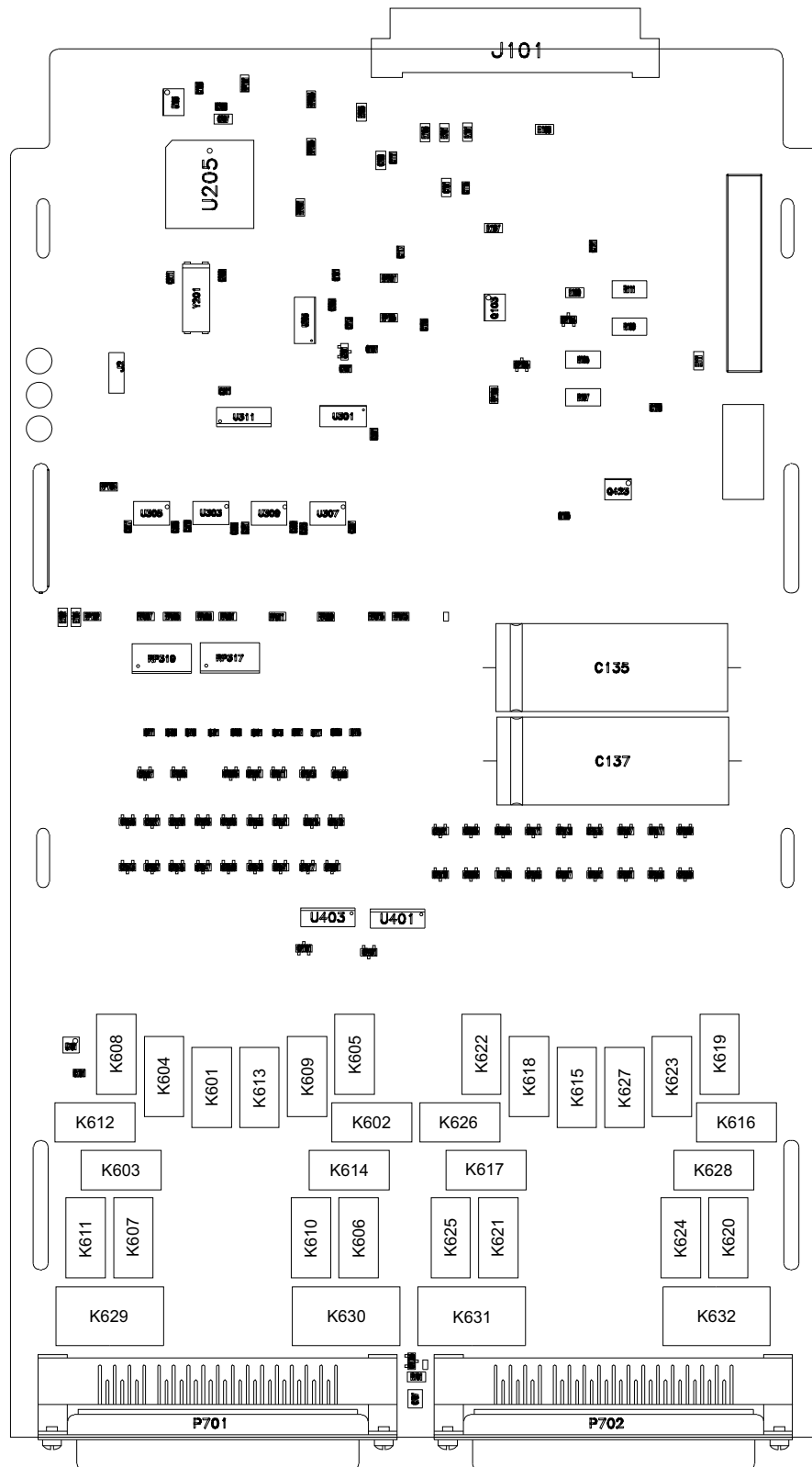

34938A Component Locator

